



Qatar Development and Trading Co.
الشركة القطرية للتنمية والتجارة

AVIATION GROUND SUPPORT Solutions...



TL600-MIL - Lavatory Service Van



The TL600-MIL is designed to service the lavatory systems of all major commercial and military aircraft fitted with commercial lavatories. The TL600-MIL is mounted on a General Motors model NPR, cab-over designed, diesel powered chassis. A personnel lift is supplied to service lavatories that are in excess of 9 feet in vertical elevation. The TL600-MIL has a three tank system for emptying and refilling the lavatories. There is a small waste tank mounted on the rear bumper for emptying portable urinal cans. A 3" stainless steel diaphragm pump is incorporated to assist in emptying the waste from the aircraft into the waste tank.



WT600PL - Potable Water Service Truck

The WT600PL water service truck is designed to service all sizes of commercial aircraft. A man-lift option is required to service wide-body aircraft. The water tank is fabricated from 304 stainless steel and is baffled in both directions. A hinged cleanout cover is provided on the tank for easy access for rinsing of the tank. The pumping system uses an electrically actuated clutch to provide power for the hydraulic system that powers a bronze, direct drive pump. Mechanical switches at the service end of the vehicle actuate the system.



MBL - Mobile Baggage Loader



The **Phoenix MBL** is a mobile baggage loader. It is designed for the rugged nature of airport ramp operation. The chassis is a heavy duty formed chassis. The conveyor bed is also designed to withstand the rough airport environment.

The drive line consists of a heavy duty front and rear axles and can be outfitted with different engines. The conveyor has controls on both ends and the front controls are recessed. Emergency stops are on all four corners. The electric belt controls are interlocked with the transmission and hand brake.

The hydraulic system and electrical control components are in the same vicinity which makes troubleshooting and repair easier. Emergency pump, instrument gauges and non-skid decking are standard.



Qatar Development and Trading Co.
الشركة القطرية للتنمية والتجارة



G-400 - Air Starter Unit



The **GATE G-400**, is designed to withstand the abuse of today's airport applications while providing a long life cycle and maintaining low maintenance costs. With 400 PPM capacity and over 100 airports using our reliable equipment worldwide, Gate became a world leader in the GSE market. Also, please find some other airport related truck.....

Catering Trucks

The business is built upon strong engineering foundations, incorporating innovation in design, and excellence in manufacturing.

Whether you are looking for a hilight, airline catering truck, airport cleaning vehicle, or any other form of aircraft ground support equipment, you will find that our engineers are capable, and our prices are suited to your budget.



But the best thing you can do is contact us and discuss your unique requirements. You will be pleasantly surprised with our delivery, reliability and value for money!

We have a vehicle for any requirement you have. However, if we do not have something that fits the bill in our current range, we are quite happy to discuss the possibility of manufacturing something especially for you.

Ground Support Equipments

QDT has been supplying state of the art dollies and trolleys from well renowned dollies and trolleys manufacturer of US & European origins



DOUGLAS MU-Meter – Friction testing equipment on Runway



The Douglas SPD Mu-Meter is one of the enduring success stories for the compilation of runway friction reports and contaminant drag measurement data without the need for specialist towing vehicles.

A dedicated airport machine designed for harsh conditions and 24 HR operation, with tow vehicle flexibility with no special installations or dedicated vehicles required. The system uses a Windows environment software fully PC compatible and supplied with all data transfer and user friendly analytical software offering computerized results in full CAA CAP683/ICAO/FAA format. A tough case laptop with touch screen, Real Time graphical display and Operator / Vehicle Positioning Data. Available with dry run and self wetting option.

- Ideal for testing airport runways, taxiways and highways.
- The Mu-Meter consists of a small three-wheeled trailer incorporating sophisticated electronic measuring and sensing systems operating in conjunction with a touch screen laptop computer (supplied) which is carried in the towing vehicle.
- The trailer produces data which is presented on the laptop screen and which can subsequently be down loaded to an office PC.
- Fully integrated design with a powerful onboard microprocessor based system for years of trouble-free operation.
- Software uses an MS Windows© environment which is simple to use, fully PC compatible and stores a wealth of vital measurement data.
- Mu-Meter can be supplied with optional software to provide both runway contaminant drag measurement and audible GPS position and report history.
- Mu-Meter produces automatic computerized results in a range of prescribed formats (CAA/FAA/ICAO etc) and in the chosen language of the operator.
- The Mu-Meter can be operated in both dry and self-wetting modes and will provide accurate day-to-day measurements as part of a runway maintenance plan.
- Another added advantage is it does not require a specialist tow vehicle or a dedicated van conversion.



- Results combine the effects of contaminant drag* and immediate – weather related – friction reports for operations management. *optional
- Douglas SPD will also be happy to arrange a demonstration of the Mu-Meter Mk6's capabilities on site.



ULTIMA SCARECROW Bio-Acoustic Systems - Effective Airside Bird and Wildlife Dispersal

A unique Tablet Computer controlled development from the well established vehicle based Scarecrow Premier 1500 bird dispersal system. Operation is simplified by user selectable languages and others can be specified to special order.

The 21cm (8.4") touch screen can display a database of bird recognition information, including full screen illustrations to aid identification. Ultima self-learns the routine of each Operator, also remembering, for example, prominent species present airside and the various sound levels previously used at GPS dependant airside locations. Ultima establishes proof of dispersal procedures completed in real time, logging Operator, species, time and date; its inbuilt GPS function logs the vehicles airside position from which dispersal took place.



Ultima is a complete system, including roof mountable loudspeakers, Tablet mounting brackets, microphone for live announcements, back-up control unit and hot-pluggable USB flash drives to enable data captured to be transferred from the vehicle to the airfield analysis system for which audit software is provided.

The flash drive can also act as an identity key for each Operator, offering proof of their use and an audit trail of

all processes to prove due diligence and to provide long term analysis of bird behavioral patterns.

In addition to the features detailed previously, the software driven basis of Ultima means that subsequent improvements and enhancements to the software can be delivered to existing system users via USB flash drive upgrade.

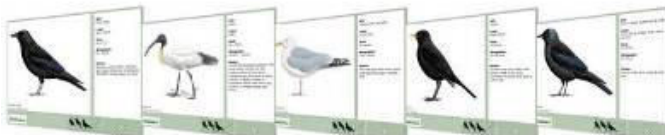
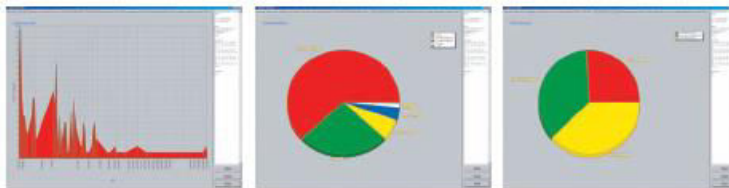



DESKO BGR – BOARDING GATE READERS

DESKO GRSU 504 - The 1D/2D scanner for mobile phones and paper-based barcodes, the Gate Reader Scanner Unit (GRSU) offers a reliable and sturdy flatbed presentation scanner for all industry 1D and 2D bar codes (incl. PDF, Data Matrix, QR and Aztec codes).

The scanner unit, especially designed for mobile phone as well as paper based bar codes, is the ideal device for mobile ticketing applications.



The DESKO Gate Reader Scanner Unit is specially designed for high frequent bar code reading procedures and can be used as a build-in-unit or as a stand alone device. It can be operated as a self service application or at a manned station.

BGR Common Features

- ◇ Fast, omnidirectional 1D/2D imager with optional ATB2 motorised reader
- ◇ Large document throat allows A4 documents to be read
- ◇ Bright VFD 2 x 16 character display
- ◇ Reads IATA recommended PDF417, 2D and linear symbologies
- ◇ Reads 2D barcode images on PDA and cell phone displays
- ◇ Single RS232 cable connection to host
- ◇ FLASH upgradeable software
- ◇ Green and red indicator beacons and audio beeper
- ◇ Options port to add receipt printer functionality



Also, we are dealing with other brand such as Access-Is, Unimark, etc

Access IS has a comprehensive range of boarding gate readers that read traditional ATB2 documents as well as the new 2D BCBP documents. Models include manual swipe and motorised ATB2 document readers, and options include the integration of OCR and RFID reading functionality for reading passport and e-passports.



Access 

The **Unimark's EC3000** is the first and only gate reader that can read and decipher every type of boarding pass coding including yet-to-come technologies such as PDA, mobile phone and photo imagin



 **UNIMARK**
PRODUCTS

Tic-Check model of EPSYS is low cost, small size, simple to operate, reliable and flexible. Accepts ATB2 coupons and boarding passes and wallets in two directions. Removable storage bin or pass through. Powerful 32-bits RISC ARM microprocessor with 64Kbytes SRAM, 256 Kbytes Flash and additional 256Kbytes external Flash memory.



EPSYS

DOUGLAS RAM - Multi Aircraft Matrix Acquisition System



The RAM MAMS system can handle all current and envisaged helicopters and fighter aircraft. Including JCA (STOVL) and Chinook options

RAM is an ultra low profile battery-electric unit designed specifically for deck and ground handling of military helicopters and fighter aircraft, especially the new generation low ground clearance aircraft such as the Lynx Mk8.

Multi Aircraft Matrix Acquisition System allows RAM to handle all current and proposed fighter aircraft and helicopters including -

- Lynx Mk8
- Merlin
- Harrier
- Apache



BRIEF SPECIFICATION

- ◇ Low profile 350mm height with 70mm ground clearance
- ◇ Multi aircraft compatibility with no modifications
- ◇ Capable of lifting 3500kgs and towing aircraft with all up weight of 25000kgs
- ◇ 3.5 hours continual movement on one battery charge
- ◇ Self contained battery charging facility





AVIATION LIGHTING Solutions...

Emergency Lights

Emergency light products for Civil & military Aviation available in the range LED, Solar and Rechargeable . Applications: * Runway Edge * Threshold and Runway End * Taxiway Edge * Helicopter Landing Zones



carmanah[®]
we put solar to work

A704-5 Aviation/Obstruction Light

Benefits

* Easy installation * Compact, self-contained design * Significant cost savings * Reduced maintenance cycles * Clean, renewable solution

Features

* Up to 44.3 cd of intensity * Optional wireless remote control with 4 km (2.5 mile) range * High-intensity visible and infrared dual-mode LEDs * Integrated carrying handle * Compatible with night vision goggles * Dusk-to-dawn or on-command operation * Available in red, green, amber, white, blue, threshold red/green, red/white, and amber/white colour outputs



OREL (Omnidirectional Runway Edge Light)

A versatile battery powered portable edge light that complies with NATO STANAG 3534. The OREL is radio controlled and emits both visual and NVG compatible light making it suitable for use during overt and covert operations.



Features

* Battery powered * 13 hours light output * NVG compatible * 3 levels of light intensity - 1 visual (50cds) plus 2 NVG compatible * Radio and manual control *

Omnidirectional light output * Instant black out capability * Withstands jet blast



COREL (Combined Omnidirectional Runway Edge Light)

A versatile battery powered portable runway light that complies with international aviation standards and is suitable for a wide range of airport or airfield applications.



Features

* Battery powered * 16 hours light output at maximum intensity * Rechargeable in approximately 8 hours * Simple drop-in charging * Up to 50cds of omnidirectional light * Lenses available in the full range of aviation colours * Manual, photocell or radio control * Flashing or steady signal * LED charge level indication * Low voltage cut-off * Can withstand jet blast

Additional Information

COREL portable runway lights can provide up to 50cds of omnidirectional white light in compliance with ICAO, CAA and FAA specifications. Easily changed lenses are available in the full range of aviation colours making CORELs suitable for use on...





Qatar Development and Trading Co.
الشركة القطرية للتنمية والتجارة

Airfield & Heliport Lighting and Fittings

We can supply of Low, medium & high intensity airfield lights comply with FAA, ICAO & NATO standards

- Approach/PAPI Lights



- Runway Lights



- Taxiway Center Line & Edge Lights

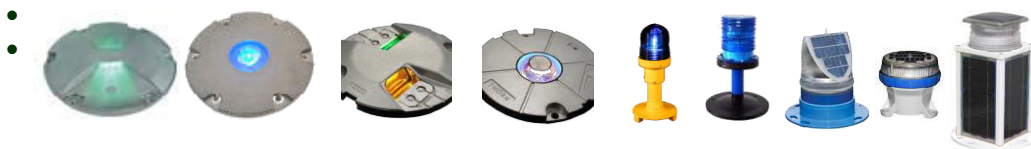

- Heliport/Helipad/HeliDeck Lights



- Different models of Obstruction lights, beacons, etc.



- Airfield Cables, Tools, Airfield Controls, Airfield Signs, Windcones & Accessories



- Other special Lamp, bulbs & tubes



AVIATION CARGO Solutions...



Semi-Automatic Baggage Strapping Machines & Straps:

Semi-Automatic Stretch Wrapping Machine is fully portable and dispenses, tightens, and seals economical polypropylene strapping around packages or bundles reater than 3". Unit automatically tensions strap and joins the ends with a secure heat weld. The motor automatically switches off when not in use. As the strap is inserted, the motor automatically restarts.



Wall plug is standard 115V single phase 15 amp.

Features:

- Minimize Packaging Time
- Secure Contents Effectively
- User Friendly Controls
- Stainless Steel Strapping Surface
- Portable for Convenience
- Easy Access for Reloading Strapping



Baggage Security Labels, Tags & Stickers

Also we supply below on request with material as per international standards

- Baggage Tags
- Special Purpose Tags
- Name Tags
- Boarding Passes
- Plastic Strip Seals
- Security Sticker with different security
- Excess Baggage Tickets (EBT)
- Revalidation Sticker
- Forms
- Cargo Manifest
- Adhesive Tape
- Cargo Document Pouch
- Club Member Cards
- Co-Mail Envelopes
- Property Sticker
- Revalidation Stickers

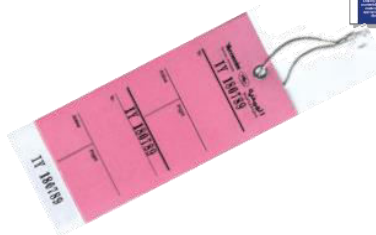



Qatar Development and Trading Co.
الشركة القطرية للتنمية والتجارة

AVIATION OPERATIONAL AREA Solutions...



Crowd Control, Store Fixtures, Signage, Retail Displays, etc.



Public Guidance:

Beltrac stanchions are patented architecturally acclaimed public guidance posts. Constructed from a continuous extrusion attached to a weighted steel base, our Beltrac line of Public Guidance stanchions will withstand years of use in the field. Each Beltrac post is equipped with our unique, industry-first 4-way dovetail groove designed to receive retractable belts or other attachments. To protect flooring in the queuing line, all posts are supplied with a standard non-marking rubberized base. Designed and built in the U.S.A.

Traditional stanchions are classically styled crowd control posts, utilizing swag ropes to create a queuing line. Available in Solid Brass, Stainless Steel and a variety of painted (powder coated finishes). Our extensive variety of portable posts will enhance any decor. All posts are factory assembled and include a universal ring that accepts swag ropes from any direction.

Retractable Belt Closures are available with 7', 13' and 18' belts. The units are attached to the wall with efficient, small dimension back plates. These units are ideal for cash register closures, hotel corridor barriers and warehouse safety aisle closures and are available in variety of finishes and belt colors.



Tarmac / Terminal Barricade Portable Unit

Instant safety for the tarmac. An instant barricade that clearly defines safe areas during boarding on the tarmac. Available as either a portable or wall-mount unit, JetTrac™ can cordon off an area as large as 65' x 65'. Swiveling belt mechanisms allow for belts to extend in any direction, minimizing belt abrasion. Belts are easy to replace, weather-resistance and anti-static.



JetTrac™



- Swiveling dual belt housings allow belts to extend in any direction.
- Self-hooking belt ends can be attached to any stationary object.
- Large wheels for ease of transport by a single person.
- Heavy-duty design stands upright even in windy conditions.
- Compact design takes up little storage space.
- Red casing with 65' belts in safety yellow.

Hand Sanitizer Dispenser

Instant Hand Sanitizer Dispenser conveniently dispenses a non-allergenic, hospital-strength hand sanitizer that kills 99.9% of the most common disease-causing germs on the spot. It utilizes an alcohol-based self-evaporating solution, enabling hand sanitizing without the need for water, soap or towels. The dispenser works with gravity, not moving gears, lasting many years and requiring only minimal battery power.



Premium Sign Frames



Premium Sign Frames & Sign Inserts

Lavi features exclusive sign frames for mounting on top of crowd control posts. These frames are fabricated with radius corners, eliminating sharp edges near your customers. Each frame includes twin clear acrylic panels designed to accept regular paper media. Elegant sign stands feature a universal ring that accepts swag ropes from any direction. Frames are fabricated with radius corners, eliminating sharp edges near your customers. Each frame includes twin clear acrylic panels designed to accept regular paper media.



Smooth radius corners eliminate sharp edges near your customers.

Lavi Industries' sign frames are strong and durable yet stylishly designed. Sign Frames can accommodate an array of media options ranging from changeable letters to standard inserts. We offer a wide variety of sign frame sizes and options. Radius corners are standard for signs used on our Traditional and Beltrac stanchions to ensure your customers' safety.

Lavi Industries features exclusive sign frames for mounting on top of crowd control posts. These frames are fabricated with radius corners, eliminating sharp edges near your customers. Each frame includes twin clear acrylic panels designed to accept regular paper media.



Light Duty Sign Frames

These attractively priced frames serve your signage needs when less customer traffic is anticipated.

Sign Inserts

Sign panels provide an easy means of communicating with your customers. With our rapid in-house sign making capabilities, your custom message or graphics are just a phone call away



OTHER AVIATION Solutions...

WindSock

Our highly visible and durable windsocks are made of Fluorescent vinyl coated fabric or international orange nylon cloth which has been treated with a water repellent and a UV inhibitor. Then double-stitch every seam with weather resistant nylon thread

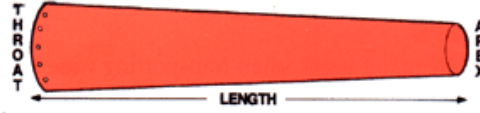



Qatar Development and Trading Co.
الشركة القطرية للتنمية والتجارة



Environmental
Environmental
Solutions



Qatar Development and Trading Co.
الشركة القطرية للتنمية والتجارة

ENVIRONMENTAL Solutions...

Specialized Industrial Vehicles

Elgin Sweeper Company is the leading manufacturer of sweepers for municipal, contractor, airport, and industrial sweeping needs. Elgin Sweeper offers the world's broadest selection of street sweepers including mechanical, vacuum, and re-circulating air models. Since introducing the world's first motorized mechanical sweeper in 1914, Elgin Sweeper has brought its sweeping technology to customers worldwide.

ELGIN Crosswind Series - Top performance on and off the Runway



Airports require sweepers that achieve top performance on the runway. To address these needs, Elgin Sweeper introduced the FSX "Fast Sweeping Crosswind." The FSX cleans at higher sweeping speeds on runways.

The FSX features a turbo charged auxiliary engine and a unique pickup head and impeller capable of incredible suction power at higher speeds. Options include heavy duty caster wheels for the pickup head and a powerful lateral side air blast (single or dual) which directs a concentrated, high velocity air stream through an opening to clear away debris from protruding lights and other obstacles where side brooms can't reach.

Auxiliary Engine	John Deere 4045TF 115 hp
Vacuum System	20,000 cfm 567 m3/min
Dumping Height Max.....	ground level
Sweeping Speed	15 mph
Hopper Capacity :	8 cu. yd. 6 m3
Sweeping Path Max:	12.8 ft. 3658 mm
Water Capacity:	240 gal 908 l
Dump Location:	Rear
Chassis	Conventional or Cab-Over
Travel Speed	Highway Speeds



ELGIN Whirlwind Series - Suited for **Municipalities, Contractors and General Maintenance Sweeping**



Looking for a truck mounted vacuum sweeper with outstanding quality and performance?

Elgin Sweeper Company has the solution. The new Whirlwind MV combines a proven low maintenance design with an extra-wide sweeping path, and a short wheelbase. The Whirlwind offers incredible pick-up performance and flexibility that has become a world standard. From the unique extending nozzle to the overall robust construction, the Whirlwind has been designed and manufactured to the exacting standards that have made Elgin the world's leading sweeper manufacturer. Customized with your choice of options, the Whirlwind is sure to fit your needs.

The Whirlwind is specially suited for general street sweeping and catch basin cleaning. Passed rigorous PM10 rule 1186 testing.

Auxiliary Engine.....	John Deere® 4045TF150 115 hp
Dumping Height	Ground level
Sweeping Path Max.....	12 ft. 3658 mm
Hopper Capacity	8 cu yd 6 m3
Water Capacity	335 gal 1268 l
Dump Location	Rear
Chassis	Conventional or Cab-Over
Travel Speed	Highway Speeds

Parts for Sweepers

- | | |
|--|----------------------------------|
| 1. Pro-Sweep Tube Broom | 13. Poly Sweep Gutter Brooms |
| 2. Pro-Strip Broom | 14. Aluminum Sweep Gutter Brooms |
| 3. Heavy Duty Sweep | 15. Aggressor XR Gutter Brooms |
| 4. Combo Sweep Tube Broom | 16. Aggressor XT Gutter Brooms |
| 5. Saver Sweep Broom | |
| 6. Section Sweep Broom | |
| 7. Whirlwind Pro Sweep Extension Broom | |
| 8. Whirlwind Combo Sweep Extension Broom | |
| 9. Crosswind Poly Center Broom | |
| 10. Crosswind Combo Center Broom | |
| 11. Pro-Sweep Gutter Brooms | |
| 12. Saver-Sweep Gutter Brooms | |





Qatar Development and Trading Co.
الشركة القطرية للتنمية والتجارة

ELGIN Pelican Series - Waterless Advantage... combines
Maneuverability, Economy & Serviceability



Purchasing a three-wheel broom sweeper? Consider the enduring qualities of the Elgin Pelican. The Pelican offers legendary performance, maneuverability, economy, reliability, and serviceability.

The Pelican is now available with three optional alternative fuel systems, Compressed Natural Gas (CNG), Liquefied Petroleum Gas (LPG), and Liquefied Natural Gas (LNG). The Pelican also has a waterless dust control option.

Engine.....	John Deere® 4045TF150 99 hp
Dumping Height Max	Variable up to 9 ft. 6in. 2895 mm
Sweep System	P - Hydraulic
.....	SE - Mechanical
Dump Location	Front
Chassis	Elgin Exclusive
Sweeping Path Max	10 ft. 3048 mm
Turning Radius	15 ft. 4572 mm
Hopper Capacity	3.6 cu. yd. 2.8 m3
Travel Speed	20 mph 32 km/hr
Water Capacity	220 gal 832 l

Parts for Sweepers

17. Conveyor Belt

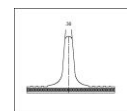
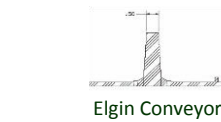
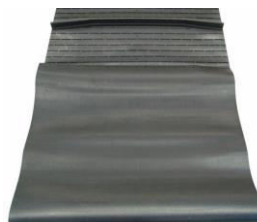

Spare Parts for Sweepers

Contacts us for spare parts orders



FOD (Foreign Object Damage) - Specialized Sweepers for Airfields, Sports Tracks and Military Bases.

A revolutionary new system of removing FOD that sweeps faster and more efficiently than ever before. This remarkable speed sweeper controls FOD such as nuts & bolts, washers, rivets, stones, loose baggage hardware, sand & empty drink containers.



The FOD*BOSS works by capturing debris as it passes over the tarmac. The force of friction and a series of specially designed brushes scoop up foreign objects and hold them in an easy to empty mesh capture zone. With a sweep width of 2.4 meter (8 feet) at speeds from 6 kph (4 mph) to 40 kph (25 mph).

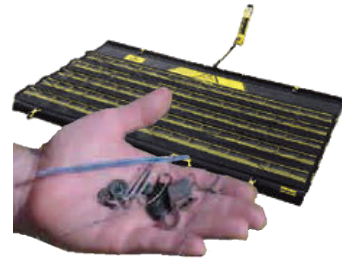

View a comparison of the FOD*BOSS to a traditional Suction Sweeper

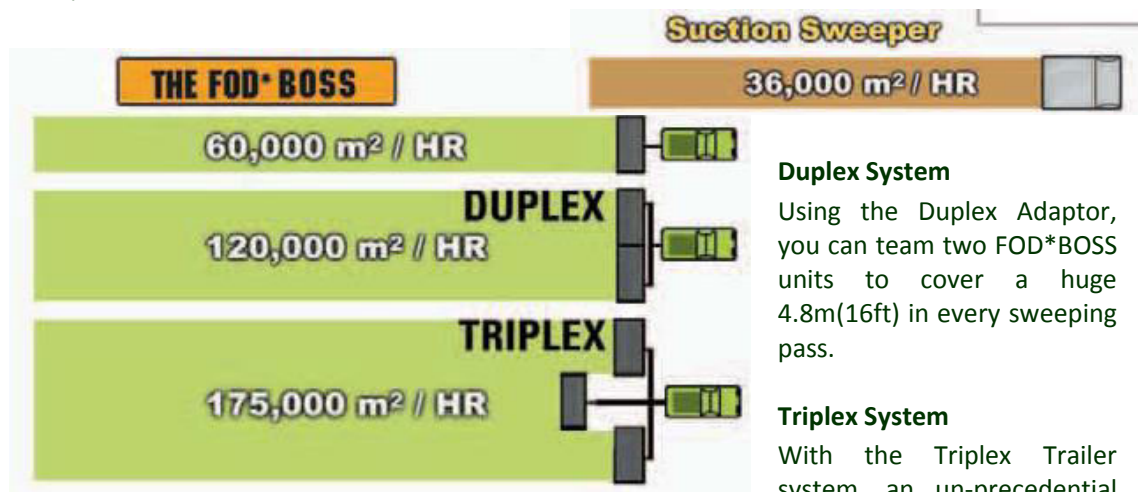

Military Operations

The FOD*BOSS is a precision FOD Sweeper proven to be outstanding in its ability to prevent damage to the highly vulnerable Jet Engines of Fighter Aircrafts. The compact FOD*BOSS units preparing for military exercises at short notice.



Race Tracks and Proving Ground

Debris such as rubber, sand, stones and metal are extremely hazardous to performance racing vehicles. The FOD*BOSS is the fastest and most efficient sweeper capable of collecting ALL these debris from racetracks. Used before racing, in between events, or as a rapid response sweeper after an accident or run-off, it is highly maneuverable and can be towed by a 4 wheel quad bike or golf cart.





VACTOR
Subsidiary of Federal Signal Corporation **Combination Sewer Cleaners**



Looking for a tough, efficient and dependable positive displacement sewer cleaning machine?

The Vactor 2100 Series combines power and reliability with customer configurable design that handles any cleaning application with speed and thoroughness.

The powerful synergy of Vactor's unique telescoping rotating hose reel and telescoping boom create the most efficient work system in the industry. The 2100 Series offer Vactor's system of integrated components. The single piston Vactor pump delivers the cleaning power and efficiency where it counts, at the nozzle, because it's the only pump specially designed for cleaning sewer lines. Vactor's unique Modu-Flex® system includes a powerful direct drive rotary lobe blower, the exclusive jet rodder water pump, a telescoping, rotating reel & hydraulic boom, and options such as the Multi-Flow water system, Shark High Performance Hose and High Performance Nozzle.

From its direct drive rotary lobe blower to the patented Vactor water pump with Jack Hammer® action that scours pipe clean, the 2100 series is designed and manufactured to the exacting standards that have made Vactor the world leader in sewer and catch basin cleaning. Every Vactor component is engineered to produce unmatched efficiency and maintenance free operation.

Design	Exclusive to Vactor Modu-Flex®
Blower	Roots / Dresser Positive Displacement
Drive	Chassis Driven, Direct Drive
Inlet Volume	Up to 4500 cfm at 2200 rpm
Vacuum Rating	Up to 18 in Hg 457 mmHg
Transfer Case	Beltless, continuous, rated to 425 hp
Fully Hydraulic Boom	Cylinder Actuated Movement
Pickup Hose	Diameter 8 in 203 mm
Water Pump	Vactor Jet Rodder®
Water Tank Capacity	500-1500 gal 1893-5678 l
Water Tank Construction	Aluminum 10 yr. Warranty
Rating	100 gpm at 2500 psi
Delivery at the Nozzle	60-80 gpm at 2000-2500 psi
Pump Action	Continuous flow or jack hammer
Pump Operating Speed	13 cycles/min
Rear Door	Full Opening, Hydraulic Latching

INDUSTRIAL CLEANING / HIGH PRESSURE WASHER MACHINES

Scrubbers/Dryers:

Scrubber systems are a diverse group of air pollution control devices that can be used to remove some particulates, gases from industrial exhaust streams. Scrubbers are one of the primary devices that control gaseous emissions, especially acid gases. Scrubbers can also be used for heat recovery from hot gases by flue gas condensation. Also scrubbers are available in two forms – Ride-on scrubbers Walk-behind Scrubbers.

Ride-on Scrubbers



Walk-behind Scrubbers



High Pressure Washer:



High pressure washer are mechanical sprayer that uses high-pressure water (hot & cold) to clean and remove mold, grime, dust, mud, and dirt. We are trading with various models of such machines. "POSEIDON" models are fabulous and durable.

Floor & Carpet Care:

Duplex is the best name for indoor floors care. Machines are available for Commercial Floor Care, Industrial Floor Care, Steam Cleaning, Steam Mopping Systems, Industrial Steam Cleaning, Hot Water Washing Systems and Escalator Cleaning.



WASTE MANAGEMENT



Waste & Bale Compactors:

Delitek Marine Waste Compactors in stainless steel for mixed consumer waste and garbage, designed for use onboard ships and offshore installations. They are built with container capacities of 0.5 and 1.5 cubic metres respectively and compaction forces up to 15 tons. The waste is compacted directly into mobile container(s), fitted with a specially designed bag, which, if necessary, can be sealed and stored onboard. High capacity **Bale Compactors** for recyclable waste

from packaging such as paper, carton (cardboard) and PVC materials. Both bale compactor versions are made as stainless steel.



Glass Crushers & Oil Filter Compactors:

The Glass Crusher is designed for crushing glass bottles. With its large capacity it is well suited for passenger vessels, accommodation installations & onboard waste management stations. **Can / Oil filter Compactor** combined compactor for used oil filters and volume reducer for paint buckets. A powerful hydraulic compactor that completely empties the oil filters. The extracted waste oil from the filter is drained into a separate tank or barrel and delivered onshore.



Other waste Handling & disposing Containers:



Our model **ELKOPLAST** waste containers and other equipment for waste handling and disposal. We supply containers for the collection of sorted waste, roll-off containers, bale presses, plastic containers and waste bins. They will attract your attention thanks to their high quality, long durability and favorable price.



DECORATIVES & UTILITIES

Ceramic wares:



We also supply small to bigger in size **Ceramic Products** such as

- Waste Bins
- Vases
- Amphora's
- Balls
- Aquila etc, etc which are made in Europe.

Product form Postorna became very popular in whole Europe and supplies went even to South America. The best known were supplies for significant church and public buildings in Vienna and other towns of Austria-Hungary (for example

Cathedral of Saint Stephan in Vienna, Moravia palace in Brno and many others).

All products of our company are made for wide area of usage. The advantage of our products is in using of high-quality, natural and ecologic materials that are very comfortable and of course cheap. The level of quality corresponds with norms of the EU and it is kept under very strict controls of the State Testing Institute in Plzen. But there are even higher levels of quality inherent in our products that make us a very good competitor for the best European producers.





Qatar Development and Trading Co.
الشركة القطرية للتنمية والتجارة

OTHER UTILITIES

Cigarette bin / External ashtray for wall mounting & Free Standing:

Wall Mounted Ashtray for cigarette butts. Heavy duty construction in stainless steel. Elegant design, 3 litre capacity with lock. Ash Tray Wall Mounted - Outdoor Stainless. No more cigarette ends littering around your entrance way or smoking area. Size: 26.5cm x 30cm x 9cm (width, height, depth). Suitable for outdoor areas and entrances. Ideal for entrances to bars, pubs, restaurants, hotels, offices and work areas. Freestanding or floor bolted high capacity bin. All parts made from high grade 304 stainless steel. Weather resistant, Heavy duty lock, Removable internal tray allows easy emptying., Small holes allow easy extinguishing., Depositing holes prevent litter from entering, Full colour packaging and fixings provided. Embossed cigarette symbol. Approx 10000 capacity.





Qatar Development and Trading Co.
الشركة القطرية للتنمية والتجارة

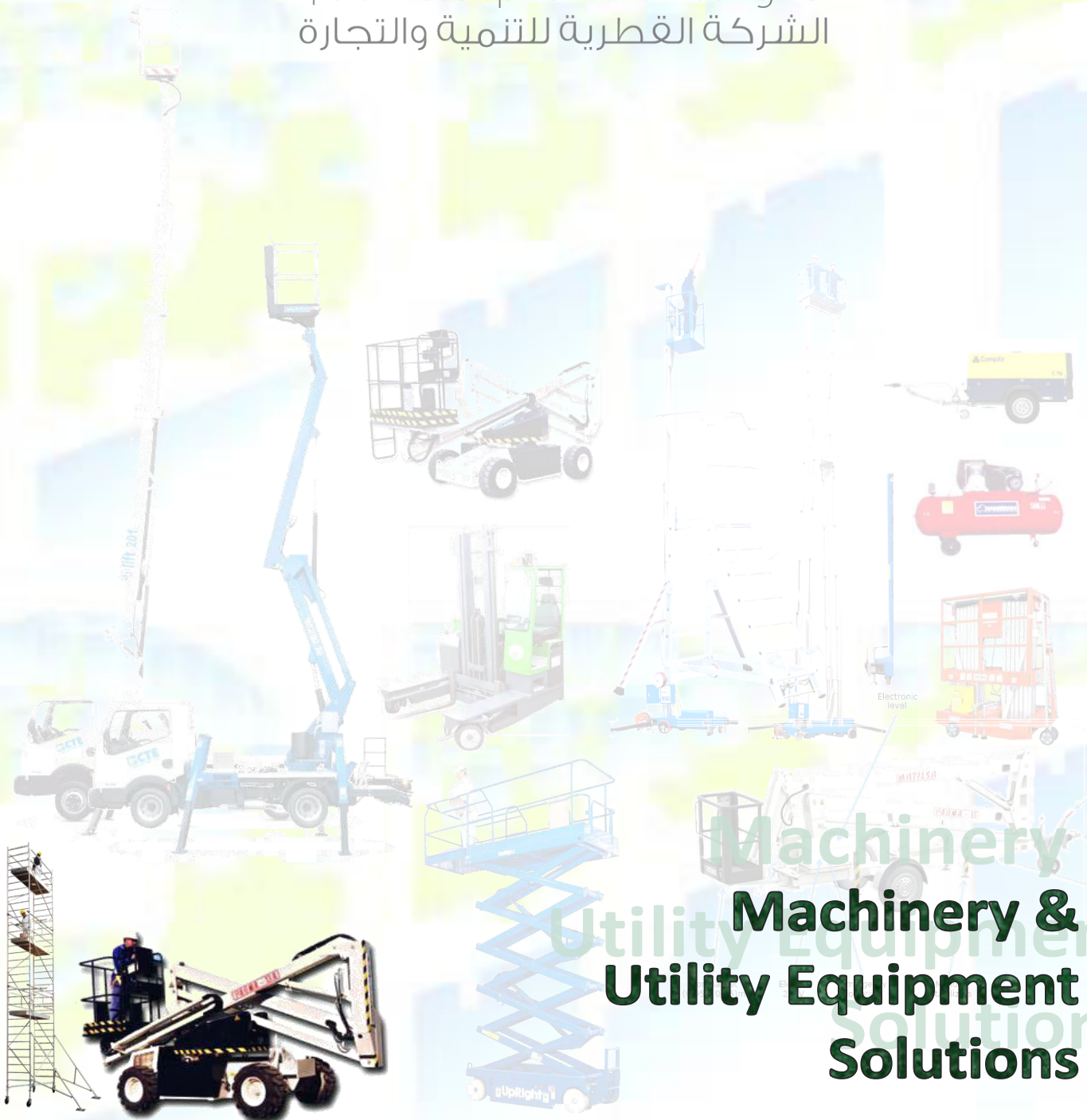

Machinery & Machinery & Utility Equipment Utility Equipment Solutions Solutions



WORKING IN HEIGHTS Solutions...

SELF-PROPELLED BOOM LIFTS

MATILSA Parma 13E – Battery Operated

Parma 13E for working heights up to 13 meter (43.30 feet). It can be driven safely with the platform at top of its height

Features

- * Declaration of conformity of machinery EU
- * Batteries machine of 205A mono block
- * Level for stabilization
- * Two-armed iron basket (1.40x0.70) meters
- * Proportional controls
- * Hydraulic leveling in basket
- * Automatic blockage in the transfer



A Standard **Parma 13E** unit



A **Parma 13E** unit with optional accessories attached to it

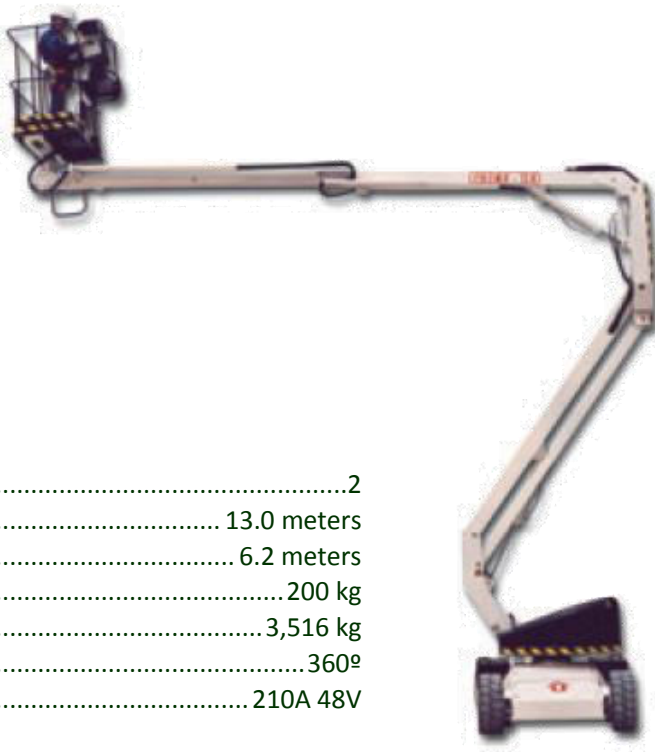

Technical Specification

- Number of persons2
- Working height 13.0 meters
- Maximum outreach 6.2 meters
- Maximum capacity..... 200 kg
- Weight..... 3,516 kg
- Rotation 360°
- Batteries..... 210A 48V

MATILSA Parma 13D – Diesel Operated

Parma 13D for working heights up to 13 meter (43.30 feet). It can be driven safely with the platform at top of its height

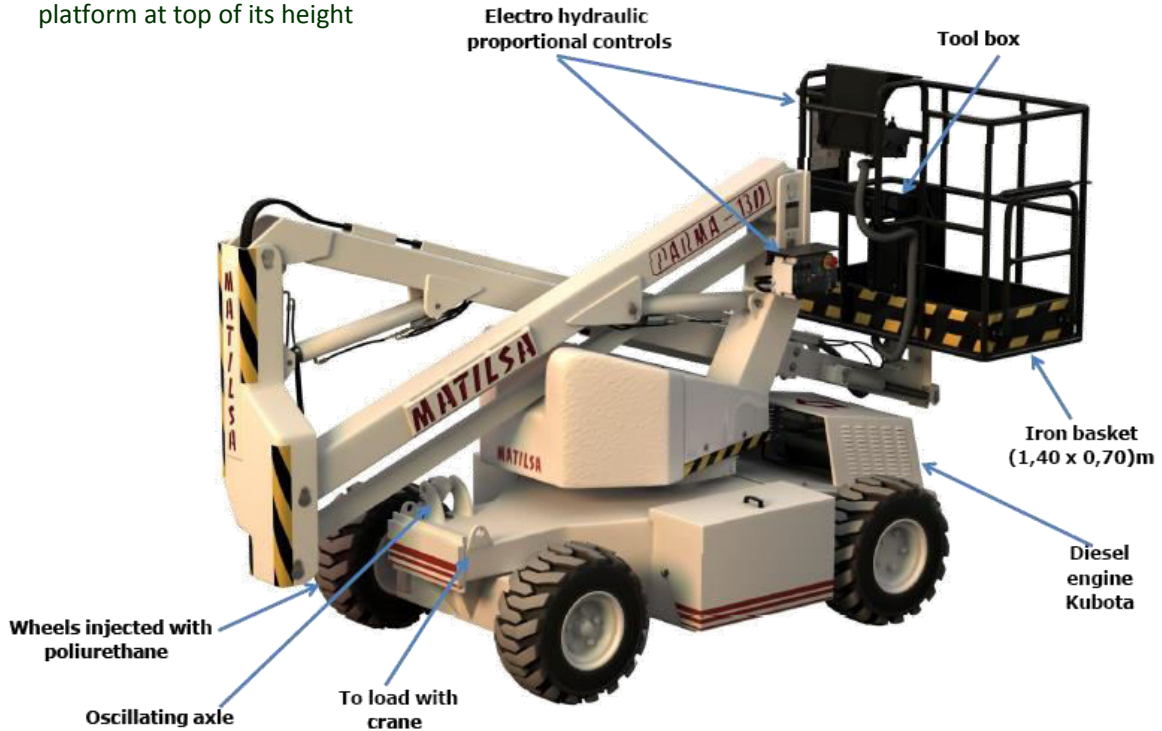

A Standard **Parma 13D** unit



A **Parma 13D** unit with optional accessories

Technical Specification

- Number of persons 2
- Working height 13.0 meters
- Maximum outreach 6.2 meters
- Maximum capacity..... 200 kg
- Weight..... 3,850 kg
- Rotation 360°
- Engine Kubota – Diesel

** Measurements are same as Parma 13E unit

MATILSA Parma 16D 4x4x4 – Diesel

Parma 16D for working heights up to 16 meter. It can be driven safely with the platform at top of its height

Features

* Acoustic inclinometer * Hydraulic rotation in basket 180° * Auxiliary movements of emergency * Wheels injected with polyurethane * Emergency lowland system * Disconnect of batteries * Anti-restart system in diesel engine * Elevation and proportional transfer * Transfer system by differentials axle * Possibility of transfer to maximum height * Pressure, temperature and alternator gauges * Oscillating axle * Four driving wheels * 4WD



A Standard **Parma 16D 4WD** unit



①

4WD



180° rotation Bucket

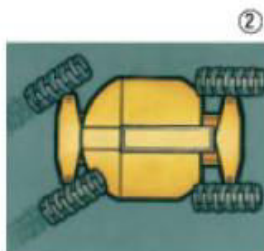

②



③



④

Technical Specification

- Number of persons 2
- Working height 15.8 meters
- Maximum outreach 7.5 meters
- Maximum capacity..... 240 kg
- Weight..... 7,320 kg
- Rotation 360°
- Engine Hatz Silent Pack – Diesel

MATILSA Parma 21D with Articulated Telescopic with Jib – Diesel

Parma 21D for working heights up to 21 meter (68.89 feet). Possibility of transfer to maximum height.

Features

- * Declaration of conformity of machinery EU
- * Pressure, temperature indicators
- * Hydraulic rotation in basket 180°
- * Auxiliary movements of emergency
- * Wheels injected with polyurethane
- * Emergency lowland system
- * Disconnect of batteries
- * Anti-restart system in diesel engine
- * Jib170°
- * Hour meter
- * Acoustic inclinometer
- * Four driving wheels
- * Four wheel steering
- * Oscillating axle
- * Elevation and proportional transfer
- * Transfer system by differentials axle
- * Possibility of transfer to maximum height
- * Hydraulic stabilizers
- * Automatic and manual stabilization



Technical Specification

• Number of persons	2
• Working height (m)	21,00
• Platform height (m)	19,00
• Horizontal Outreach (m)	12,45
• Platform size (m)(l x a)	1,80 x 0,77
• Stowed length (m)	5,40
• Overall width (m)	2,30
• Stowed height (m)	2,50
• Ground clearance (m)	0,31
• Turning radius inside(m)	1,3
• Swing	359°
• Platform rotator	180°
• Gradeability	30%
• High speed (m/sec)	1,95
• Low speed (m/sec)	0,28

Technical Specification (contd...)

- Platform capacity (Kg) 225
- Maximum manual force (N) 400
- Maximum tilt 2,5°
- Maximum wind speed (m/sec) 12,5
- Gross vehicle weight (Kg) 8.840
- Gross vehicle weight with Hydraulic outriggers (Kg) 9.508
- Diesel engine (HP) 35
- Hydraulic lifting pump Gear pump
- Hydraulic drive pump Variable
- Hydraulic filters Suction, return
- Hydraulic reservoir (l) 93
- Fuel tank capacity (l) 100

Parma 21D Outreach level

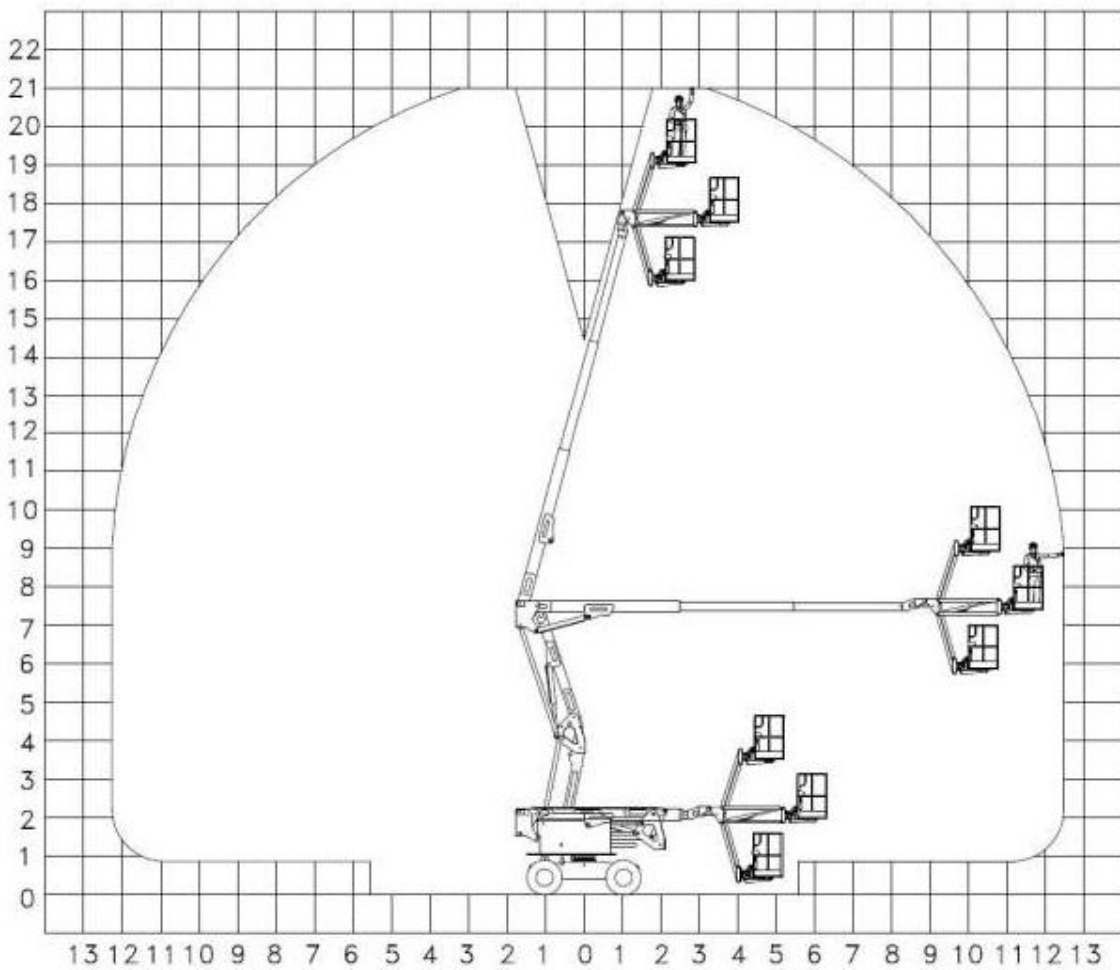

TRAILER MOUNTED BOOM LIFTS

MATILSA Parma 12 Articulated Ariel Platform

Parma 12 for working heights up to 12 meter (39.37 feet).

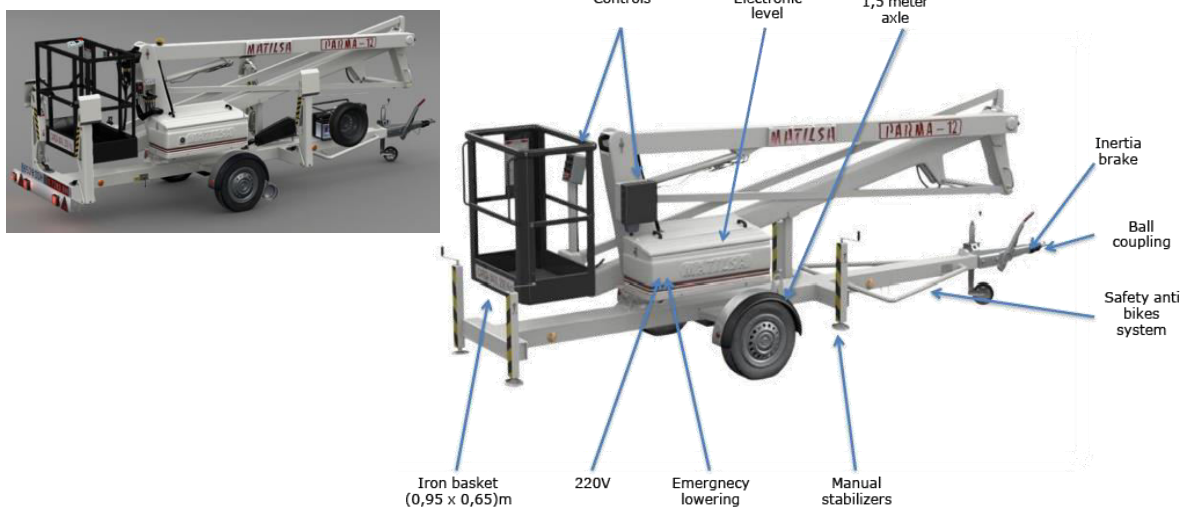

MATILSA Parma 12T Articulated Telescopic Ariel Platform

Parma 12T for working heights up to 12 meter (39.37 feet).

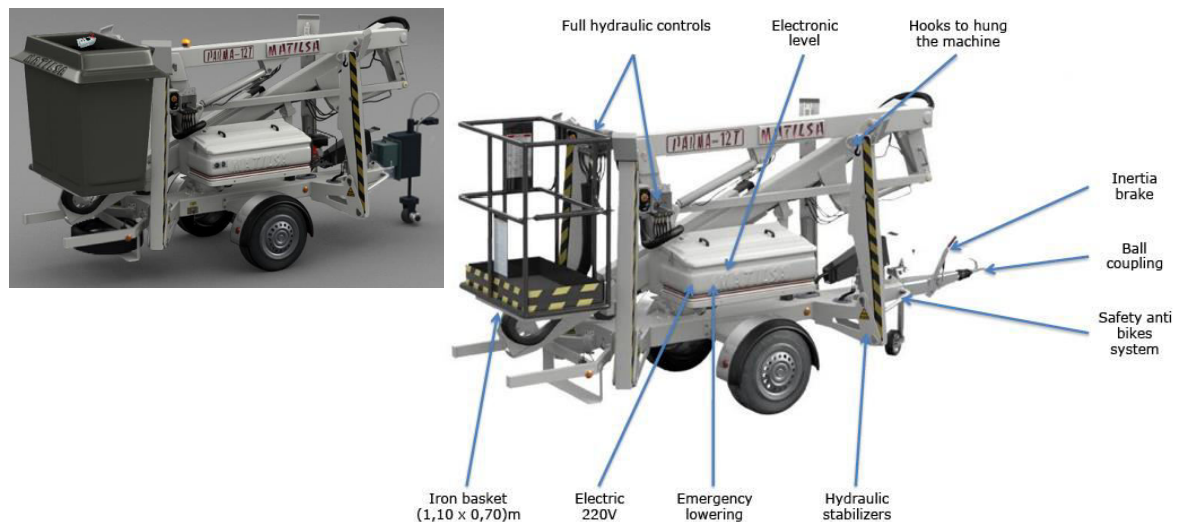

Technical Specification

	Parma 12	Parma 12T
• Number of persons	2	2
• Working height	12.0 meters	12.0 meters
• Maximum outreach	4.75 meters	6.1 meters
• Maximum capacity	200 kg	200 kg
• Gross Weight C.A.	1,200 kg	1,450 kg
• Gross Weight C.C.		1,510 kg
• Rotation	360°	360°
• Batteries	220V C.A. – 1.5kv	220V C.A. – 1.8kw

MATILSA Parma 15 Articulated with Jib Ariel Platform

Parma 15 for working heights up to 15 meter (49.21 feet).

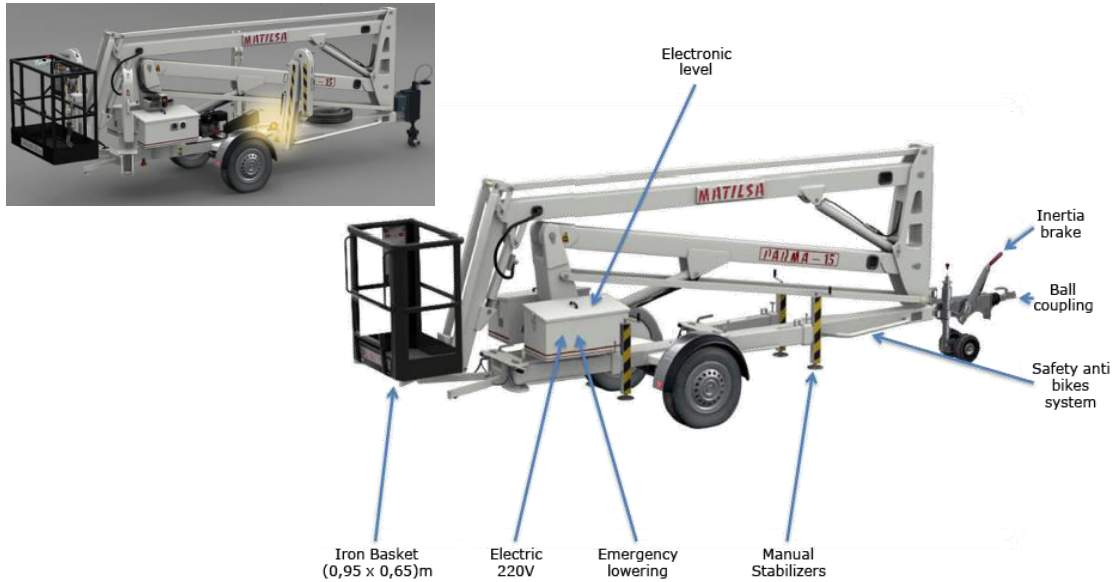

MATILSA Parma 15T Articulated Telescopic with Jib Ariel Platform

Parma 15T for working heights up to 15 meter (49.21 feet).

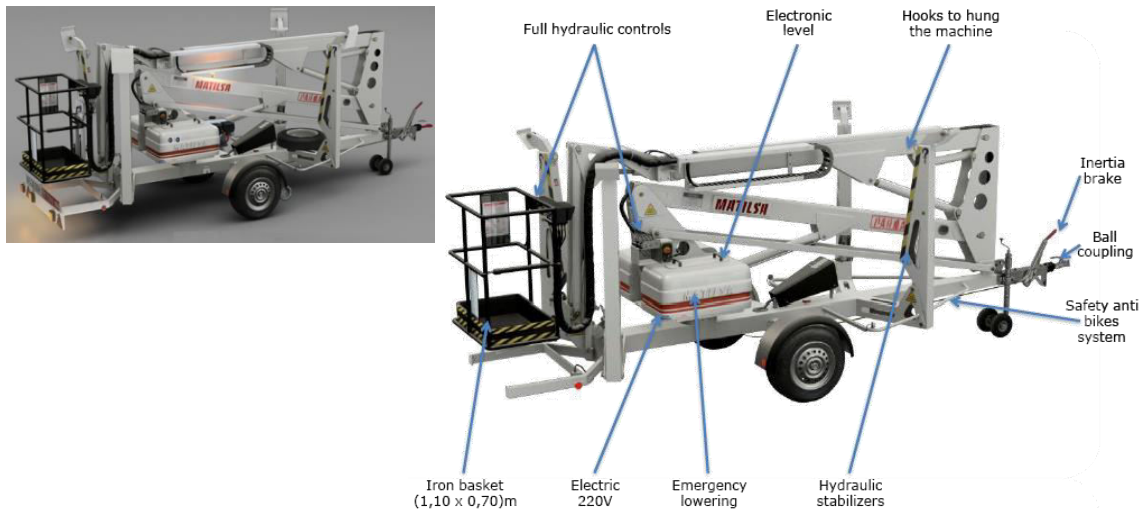

Technical Specification

• Number of persons	2.....	2
• Working height	15.0 meters.....	14.85 meters
• Maximum outreach	6.4 meters.....	7.30 meters
• Maximum capacity.....	200 kg.....	200 kg
• Gross Weight C.A.	1,580 kg.....	1,880 kg
• Gross Weight C.C.	1,880 kg.....	2,008 kg
• Rotation	350°.....	360°
• Motor	220V C.A. – 5.0kw.....	220V C.A. – 4.2kw

MATILSA Parma 17 Articulated with Jib Ariel Platform

Parma 17 for working heights up to 17 meter (55.77 feet).

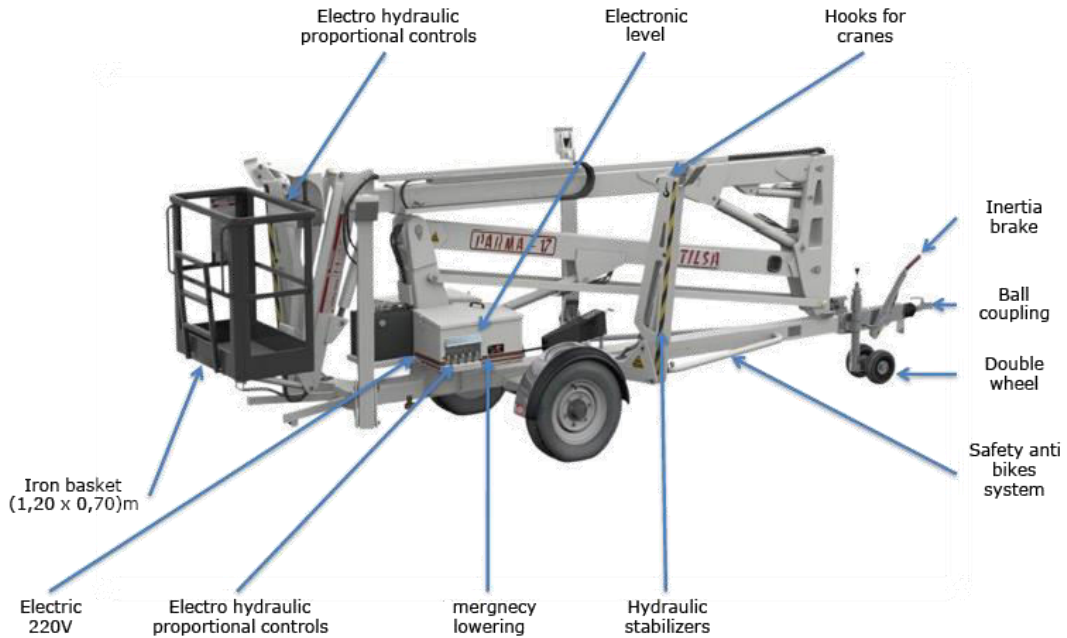

A Standard **Parma 17** unit



A **Parma 17** unit with most accessories including Galvanized Iron Basket & Articulated Hydraulic Stabilizer

Technical Specification

- Number of persons 2
- Working height 17 meters
- Maximum outreach 8.75 meters
- Maximum capacity..... 200 kg
- Gross Weight C.A.2,380 kg
- Gross Weight C.C.2,500 kg
- Rotation 350°
- Motor 220V C.A. – 10.0kw

MATILSA ACCESSORIES & SPARE PARTS

1. Trailer Coupling, Ring Type
2. Machine With Batteries Supply
3. Rotating Light
4. Emergency Descent From The Basket
5. Proportional Hydraulic Controls
6. Lighting Kit For Transport On Public Roads
7. Self Driving System, Which Acts Upon Wheels
8. Supply With Generator Set
9. Hydraulic Stabilisers
10. Descent Buzzer
11. Hour Meter
12. Charge Indicator In The Batteries
13. Self Driving System I Pole With Batteries And Charger
14. Spare Wheel
15. Fixed Axle
16. Electric Outlet In Basket
17. High Voltage Line Detector
18. Support Pads For Hydraulic Stabilizers
19. Machine With Internal Petrol Combustion Engine
20. Hydraulic Stabilizers
21. Articulated Hydraulic Stabilizers – Spider Type
22. Basket Rotating System
23. Basket With Protection Of Hands (0.94m X 0.63m)
24. Insulating Basket Of Electrical Currents (0.91m X 0.55m)
25. Iron Basket (1.20m X 0.60m)
26. Galvanized Iron Basket
27. Aluminium Basket With Overload Control
28. Basket-Load Limit Device
29. Batteries With Greater Charge Capacity
30. Aluminium Basket With Overload Control
31. No Marking Tyres
32. System For Moving On Rails
33. Bi-Energetic System – 285a
34. Bi-Energetic System – 210a
35. Automatic Leveling
36. Quick Outlet For Air & Water

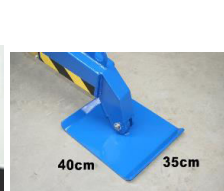
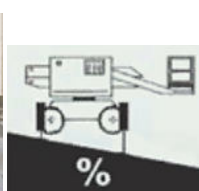

VEHICLE MOUNTED MANLIFTS

ZED 14 – Articulated Truck Mounted Platforms

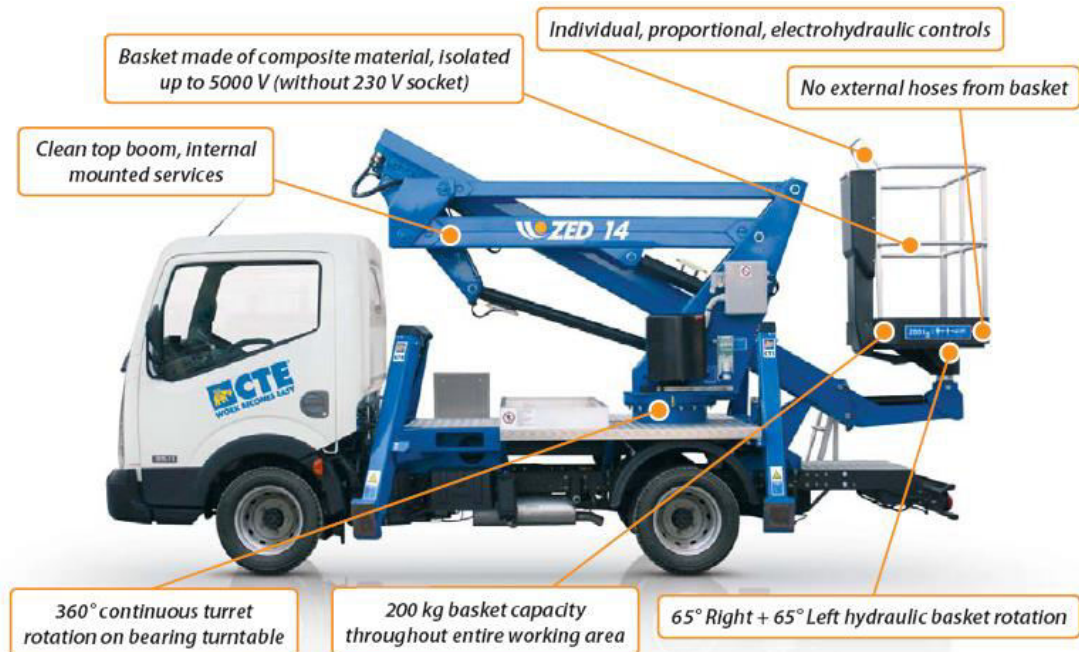

Technical Data

- Pantograph + telescopic arm
- 360° continuous turret rotation on bearing turntable
- Individual, proportional and electro-hydraulic controls in basket
- Engine start and stop controls from basket
- Anti-slip aluminium flatbed decking
- Basket base in composite material with aluminium guardrails
- 65° Right + 65° Left hydraulic basket rotation
- Automatic hydraulically actioned basket leveling
- N° 4 hydraulic outriggers with ground pressure sensors
- 230 V AC EC electrical socket in the basket
- Buzzer indicating PTO engaged
- Hour meter
- Standard boom colours blue (RAL 5017) or white (RAL 9010)
- CE certified

Technical Specification

- Working height 13,9 m
- Platform height 11,9 m
- Working outreach 7,5 m
- Capacity 200 kg
- Basket dim.1400x700x1100 mm
- GVW minimum 3,5 t

Note: other models available are Zed 17, Zed 17 L, Zed 19, Zed 19 L, Zed 20, Zed 20 L, Zed 20 C, Zed 21 J and Zed 21 JL

B-LIFT 201 PRO – Telescopic Truck Mounted Platforms (version with A-frame outriggers)

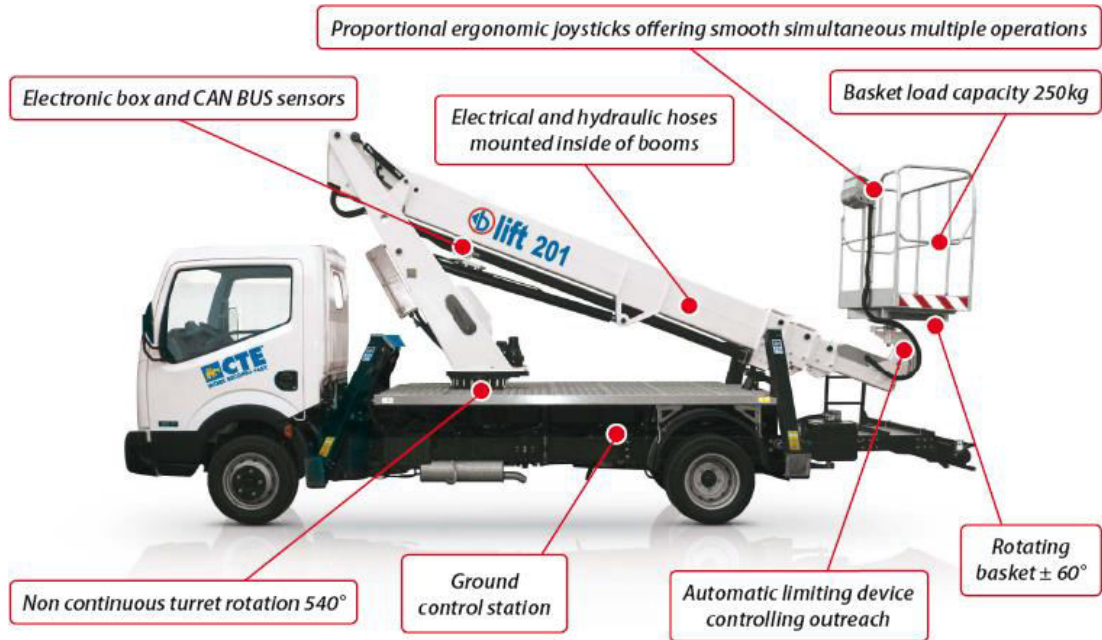

Technical Data

- Telescopic boom (Main boom + 3 telescopic extensions)
- 540° non continuous turret rotation on bearing turntable
- Proportional electro-hydraulic controls with simultaneous maneuvers.
- Engine start/stop controls from basket
- Anti-slip aluminium flatbed decking.
- Aluminium Basket
- Systems to automatically limit the outreach depending on the weight in the basket
- 60° Right + 60° Left electric rotating basket
- Automatic basket leveling hydraulic parallelogram
- N° 4 hydraulic outriggers with ground pressure sensors
- 230 V AC EC electrical socket in the basket
- Buzzer indicating PTO engaged with disconnected hand brake
- Hour meter
- 1 flashing beacon
- Ground Control station with display

Technical Specification

- Working height 20,0 m
- Platform height 18,0 m
- Working outreach 10/7.3/6.6 m
- Capacity 80/200/250 kg
- Basket dim. 1400x700x1100 mm
- GVW minimum 3,5 t

Note: other models available are B-lift 20.13 mp, B-lift 150 pro, B-lift 162 pro, B-lift 162 pro H, B-lift 187 pro A, B-lift 187 pro H, B-lift 201 pro H, B-lift 230 pro A and B-lift 230 pro H

ISOLI PNT 27.14 – Truck-mounted aerial lift work platform



Technical Data

- Basic sub-frame including welding of point 2 on connecting cross beam
- Tool box under the platform deck
- Nonslip aluminium platform deck
- Emergency descent system by means of a hand pump operated from the platform deck
- Access ladder to the platform
- Hydraulic and electric system for the sub-frame
- Paint of the sub-frame (one colour)
- Aluminium Basket
- Aluminium working basket for two persons 200 kg.- dimensions: 800x1800x1100 mm
- Isoli Controls
- Dual electro-hydraulic control panels one under the platform deck (only for emergency operations) and one in the basket with proportional operating
- Operative hour counter
- Engine start
- stop operated from the control panel in the basket and platform deck
- 1 magnetic rotating light
- Security interlock device between outriggers and telescopic boom
- Anticollision device for boom/chassis cabin and pilot signal lamp
- Chains breaks pilot lamps
- Installation on the chassis
- Rear mudguards with splashguards
- CE mark (CE type A)

Technical Specification

- Working height 26,9 m
- Working outreach 13.7 m
- Capacity (including 2 person)..... 200 kg
- Basket dim.800x1800x1100 mm
- GVW minimum 3,5 t

Note: other models available are # PNT 205 SR, PT 15.9 / 2, PT 19.9, PT 16.5, PTJ 270 S, PTJ 3522 SL, PNT 27.14, PNT 280J, MPT140 and PNT 210 J

TEUPEN Euro B 20 T – Truck-mounted aerial lift work platform



Technical Data

- Hydraulic support
- Folding props
- Drive: via Truck PTO
- Energy supply chain: inset
- Hydraulic rotating work basket: about 180 °
- Control: 2 channel load moment through Fuzzy control,
- Pressure and angle monitoring
- Technical data at up to 308 MB Sprinter CDI / 311 CDI / 313 CDI

Technical Specification

- Working height 20,0 m
- Platform height 18,0 m
- Working outreach (200 kg) 9.8 m
- Working outreach (80 kg) 12.0 m
- Rotation 270°
- Capacity 200 kg
- Basket dim.1200x800x1100 mm
- Outrigger width.....Approx. 2980 mm
- GVW minimum 3,5 t

Mass

- Overall length..... approx 8050 mm
- Overall Height 3100 mm approx
- Vehicle width 2180 mm approx
- Wheelbase : 4025 mm
- Perm. Total weight..... : 3500 kg

SCISSOR LIFTS



Standard Features

- Roll out deck extension
- Proportional controls
- Lift up rear guardrail to ease material loading
- Tilt alarm
- Swing-out service modules
- Crane and forklift points
- Cushion down scissor descent
- Selectable motion alarm
- Non-marking tyres
- Quick retract guardrails
- Horn
- Hour meter / low voltage indicator

Brands

MAST LIFTS

GTWY – Clwble / Duel / Multi Mast

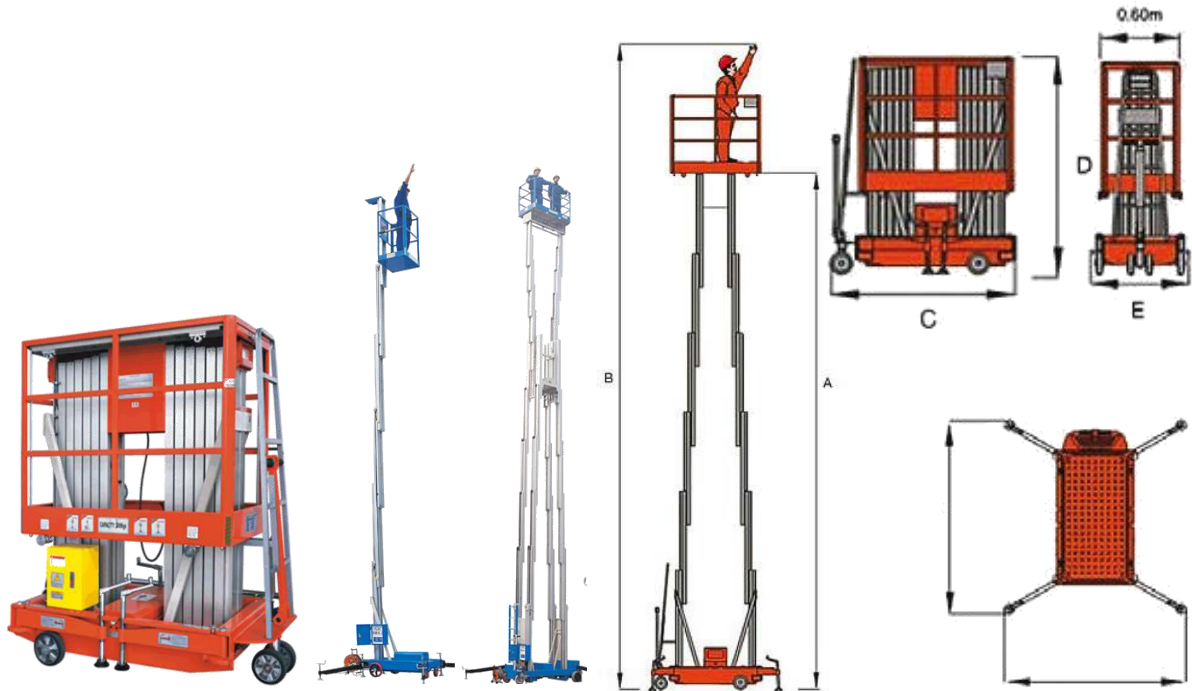

Standard Features

- Suitable for 1-2 person to work upraised with better loading capacity
- Two masts are descended or ascended synchronously; Entire lifting unit with guardrail offers such high intensity and convenient installation and disassembling that it could complete assembling or disassembling through lifting only once;
- Easy maneuvering and with straddle legs similar to that of single mast aerial work platform;
- Conforms to CE; Available accessories: mast stand, auxiliary for step use, side-sheer unit;
- Power Supply: Single phase AC as standard; DC or both AC as option

Models & Specifications

Model			GTWY 6-2000	GTWY 8-2000	GTWY 10-2000	GTWY 12-2000
Electrical Source	AC	V	220-240	220-241	220-242	220-243
	DC		12	12	12	12
Aneroid Battery		V/Ah	2×12/75	2×12/76	2×12/77	2×12/78
Charger		V/A	12/15	12/16	12/17	12/18
Lifting Motor	AC	V/kw	220/0.75-1.5	220/0.75-1.6	220/0.75-1.7	220/0.75-1.8
	DC		12/2.5	12/2.6	12/2.7	12/2.8
Overall Length			1560	1560	1790	1790
Overall Width			840	840	840	890
Overall Height			1810	1810	1810	2030
Overall Net Weight	AC	Kg	570	630	730	825
	DC		610	670	770	865

SINOLIFT GTWY – Single Mast
For material handling

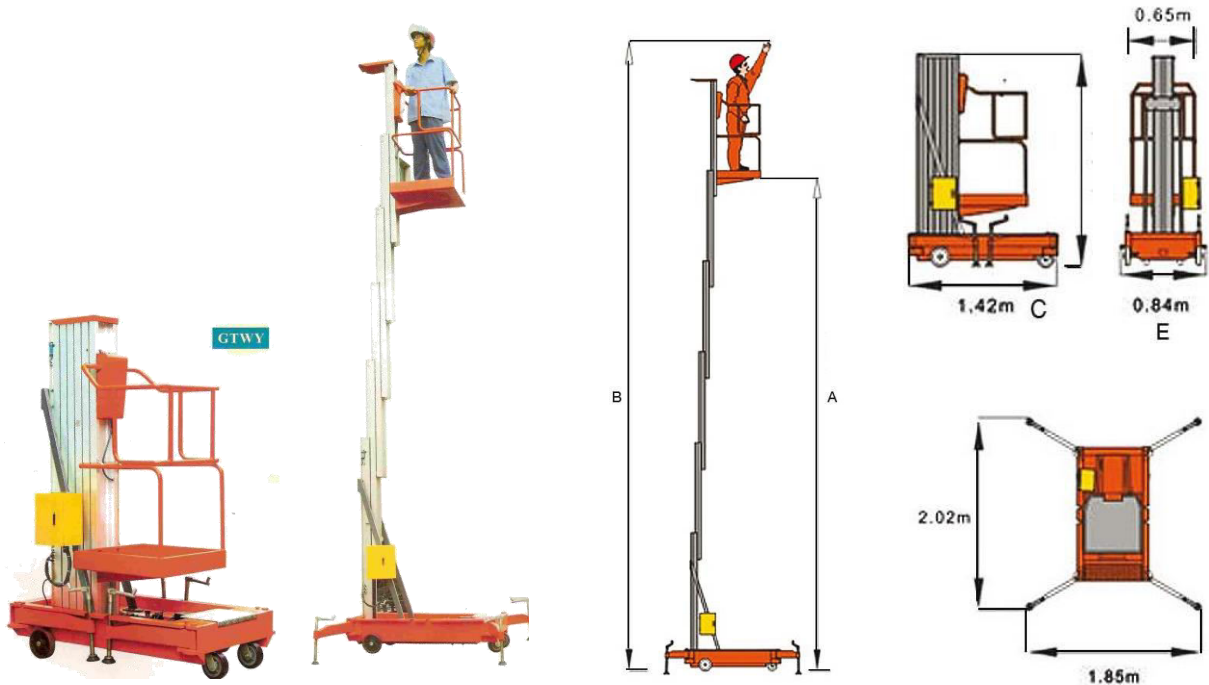

The product has passed the CE certification. It adopts aluminum mast design which is light, flexible and reliable. It is only for one person's working in exhibition hall, warehouse, supermarket, airport, port, etc.

Standard Features

- The product can be powered by DC or AC according to the order.
- The external size is small after folded. It can be moved into elevator and pass ordinary door or narrow passage.
- There are two controllers for ascending and descending.
- It has unique upper platform and lower platform design.

Models & Specifications

Model			GTWY 6-1000	GTWY 8-1000	GTWY 10-1000
Max. Platform Height		Mm	6000	8000	10000
Max. Machine Height			7350	9460	11300
Min. Platform Height			580	580	580
Ground Clearance			60	60	60
Lift Rated Capacity		Kg	150	125	125
Platform Size		Mm	630×650	630×651	630×652
Outspread Size			2030×1840	2030×1841	2030×1842
Electrical Source	AC	V	220-240	220-241	220-242
	DC		12	12	12
Aneroid Battery		V/Ah	2×12/75	2×12/76	2×12/77
Charger		V/A	12/15	12/16	12/17
Lifting Motor	AC	V/kw	220/0.75-1.5	220/0.75-1.6	220/0.75-1.7
	DC		12/1.5-1.6	12/1.5-1.7	12/1.5-1.8
Overall Length		Mm	1420	1420	1420
Overall Width			840	840	840
Overall Height			1920	2040	2040
Overall	AC	Kg	375	410	440
	DC		415	450	490

LOADING DOCK LIFTS



LoMaster Series – Stationary Dock Lifts

Standard Features

- Remote power pack 12' (3,658 mm) hydraulic hose (3 phase, common voltages).
- Push button control on 12' (3,658 mm) straight cord.
- Hydraulic pump with built-in overload relief.
- Hydraulic and oil hoses included.
- Up-travel limit switch.
- Motor, controls, push button factory pre-wired & tested (UL/CSA approved).
- Full length deck beam for maximum support.
- Solid plate steel legs for maximum rigidity.
- 8" (203 mm) tapered toe guard protection on stationary models only.
- Handrails with 4" (102 mm) kick plate and barrier chain across both ends.
- Checkered deck and 18" (457 mm) long lip with lifting chain on rolling end.
- Hard chromed pivot pins at cylinder and center pin.
- All pivot points equipped with maintenance free lifetime lubricated bushings.
- Scissor leg roller bearings maintenance free.
- Precision safety velocity fuses on hydraulic cylinders to prevent platform freefall.
- Mechanical, hinged to frame, flip-down maintenance stop on stationary models only.
- Completely sealed, weather resistant cylinders vented back to hydraulic tank to prevent contaminant entry into cylinder.
- Complies to ANSI MH29.1 standards.



LoMaster Series – Semi-Portable Dock Lifts



In the event you find the cost of forming a concrete pit/pad expensive, an economical solution is a LoMaster Semi-Portable Dock Lift. The unit is installed at the dock face and mounted on locating cradles and wear plates. With its extremely low profile, the LoMaster Semi-Portable Dock Lift provides added versatility for ground level loading/unloading operations.

The same high quality construction features found in the stationary models are incorporated into all LoMaster Semi-Portable Dock Lifts. Each lift cylinder is encased in a weather-resistant, all steel housing. Precision velocity fuses on each hydraulic cylinder eliminates platform free-fall. All

hard chromed pivot points are fitted with lifetime-lubricated bearings or Teflon coated bronze bushings. Indicator sensing bars and high visibility striping provide four sided toe protection. Sturdy steel handrails with 4" (107 mm) kick plate and barrier chains at both ends provide added operator safety. An 18" (457 mm) long lip with lifting chain on the rolling end is standard.

Minimal maintenance and product longevity - put a LoMaster Semi-Portable Dock Lift to work at your facility.

FORK LIFTS



C4000E – upto 4 tons – Electric driven

Technical Specification

• 1a Max. Lift Height	4040mm
• 1b Free Lift Height	0mm
• 2 Height Mast Closed	2855mm
• 3 Max.(Mast raised)	4870mm
• 4 Overall Length	2300mm
• 5 Mast Travel	1250mm
• 6 Ground Clearance Under Mast	20mm
• 7 Ground Clearance to Centre of Wheelbase	200mm
• 8 Height Over Cab (without work-lights)	2585mm
• 9 Width	2360mm
• 10 Outside Spread of Fork Arms	1350mm
• 11 Track Front	1965mm
• 12 Frame Opening	1400mm
• 13 Load Centre Distance	600mm
• 14 Overhang Front	245mm
• 15 Wheel Base	1915mm
• 16 Overhang Back	140mm
• 17 Length From Face of Fork	1100mm
• 18 Approach Angle	45°
• 19 Ramp Angle	17°
• 20 Departure Angle	45°
• 21 Forward Tilt	3°
• 22 Backward Tilt	5°
• 23 Minimum Outside Radius	2345mm
• 24 Platform Height	495mm
• 25 Platform Length	1200mm
• A Capacity	4000Kg
• B Unladen Weight	7600Kg
• C Maximum Ground Speed	10 km/h
• D Gradability	10%
• E Battery Capacity (V / Ah)	72V / 775 Ah
• F Fork Section	50 x 150 x 1200mm
• G 16 x 7 – 10.5 Front Tyre (Solid)	OD 406 / Width 178mm
• H 27 x 10 - 12 Rear Tyre (Super Elastic) OD 680mm / Width 255mm
• I Standard Colour	Green and Grey
• J Suspension Seat	KAB Model 116



OTHER “WORKING-IN-HEIGHT” EQUIPMENTS

Special Ladders & Scaffoldings:

TUBESCA Special ladders are articulated, folding, retracting combination ladder, this step ladder truly is a Giant in the world of ladders. Acts as an ‘aluminium extension ladder’, as a ‘stairwell ladder’. The Platforms - Low level stable work platforms which are height adjustable and are available in a wide range of models. The Aluminium Scaffold Towers – Lightweight alloy towers used extensively in the construction industry. A portable scaffold tower offers a level of safety when other access equipment is not suitable.



OTHER EQUIPMENTS

Welding Machines:

In both DC and AC mode this our welding machines will give an excellent start and stable arc with lowest possible noise without compromising the weld result. All type of material and thickness can be welded with the highest quality. Also offers a wide range of accessories



Mobil Grease Kits:

Portable Grease Kit for Drums. Convient kit allows efficient dispensing of grease for high volumen applications. 4 wheel cart has reel mounting plate for future addition of reel. Retainer bracket to hold pump during change is standard.



Portable Compressors:

Compressors are similar to pumps: both increase the pressure on a fluid and both can transport the fluid through a pipe. As gases are compressible, the compressor also reduces the volume of a gas. So the main action of a pump is to pressurize and transport liquids. We deal the ranges from Piston type to Portable type.



Economical Fuel Dispensers:

CUBE pumps have been developed for the distribution of Diesel fuel in non-commercial uses and the vehicles can be refuelled quickly and safely, with various options for measuring and recording the quantities dispensed. The flow-meters mounted on CUBE pumps have sturdy mechanical readout systems whose reliability and easiness to use have been proved by time. Simple and versatile, CUBE pumps can also be installed on drums, thanks to their 2" quick couplings.



High Capacity Power Generators:

The Series design features have made Cummins diesel, the standard for comparison of operating economy, reliability and long life. When all cost factors like initial purchase, fuel, lube oil, maintenance and overhaul are considered, the bottom line will show that this Cummins 'Q23 Series' will deliver the lowest life cycle cost.



The Gen-set powered by the reliable Cummins 'Q23 Series' series diesel engine meets stringent exhaust emission tests as per MOEF norms without sacrificing fuel efficiency at normal operating loads. Cummins 'Q23 Series' series diesel engine comes with heavy duty features, optimum size camshaft, optimized turbo-matching, premium Injectors and is yet compact in size with optimum power to weight ratio making it the obvious choice for your long-term power needs.

Cummins 850-1000 kVA enclosure is so designed as to have optimum performance and serviceability over the complete operating range. The enclosure is compact with integral fuel tank and is designed for ease in maintenance. The powder coated enclosure is manufactured on latest CNC machines to ensure superior finish and durability.

Design, manufacture and testing of engine and Alternator, enclosure and other accessories is



from Cummins Group of companies for that optimum performance integrity and backed by countrywide product support network with single source responsibility for the entire package.

EMERGENCY EQUIPMENTS

Quick-Response Light Rescue Vehicle



Design features

- Rugged and useful holders and bracket for the equipment, intelligently fixed from the tactical point of view.
- Electric front roller winch WARN M 8000
- Dynawatt generator 3.5 kVA, driven via V-belt
- Zumro Stem-Lite, extended approx. 3 m, on the vehicle roof, spotlight 12 V, 4 x 100 W
- Trailer coupling Rockinger
- Equipment as requested

SPECIAL EQUIPMENTS

Gravity Centralizer

Stevedoring companies and ship-owners are today focusing on safer and more rapidly handling. With Gravity Centralizer the crane operator can change the lifting points. By finding the correct lifting point the operator can handle unevenly loaded containers without the any problem and lift them straight.

This means less risk of jammed containers in cell-guides and will increase safety and efficiency. Cost for damages goods will be decreased. The Centralizer can work with any brand of fixed frame container spreader. Extreme low tare weight, 330 kg only. Operates with both 20ft and 40ft spreaders.

The chain wheel has a patent pending integrated safety wheel blocking system that automatically prevents the chain wheel from turning when the mainsling/chains are straight due to lifting the load beneath.



SPARE PARTS

GRANTEX ■ Steel Tubular Rivets for Brake Shoes

The Series design features have made Cummins diesel, the standard for comparison of operating economy, reliability and long life. When all cost factors like

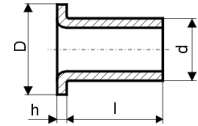

Power Steering Oil / Steering Gear Lubricant

Power Steering Oil / Steering Gear Lubricant for Mercedes Benz Cars/Vehicles. Available in 0.5L & 1.0L bottles. MB-Approval: 236.3 Steering gear oils (ATF, Specification 236.3). Made in Russia



Drum Grease Pump Assembly

Double Acting High Pressure Pump provides uniform pressure and delivery on the up and down stroke. Including, High Pressure Grease Delivery Hose 3ft (.92mtr, Air Hose, High Pressure Grease Delivery Control Valve, Rapid Disconnect Coupler, Air Nipple, Grease Hose Connection, Follower Plate, etc. etc.

Air Conditioning Pump

Used in salt water & fresh water applications. Stainless steel construction. Thermo overload protection. 220V AC ignition protected. 6' electrical wire leads for hard wire connection

1200 GALLON PER HOUR
PUMP W/ 20' CORD



Automatic Sliding & Revolving Doors:

We are importing Crawford Doors & Spareparts for same. We also supply Dorma Automatic Single Slide/Bi-Parting Doors and their spare parts. Operator is to be a 240V fully electric BWND EL300 operator, fully housed in an extruded aluminium housing (height 265 x width 152mm), Low profile (height 155mm x 230mm). The Operators must be manufactured in Australia and have at least 85% Australian content.

Cold Asphalt

EZ STREET is a polymer-modified cold asphalt guaranteed to permanently repair potholes, utility cuts, overlays, and edge repairs in asphalt or concrete. EZ STREET cold asphalt is currently being used by State DOT's across the country in bulk and bag form. Not only does EZ STREET cold asphalt work in ALL weather conditions, it even works in water.



EZ STREET cold asphalt is easy to apply and requires no mixing or tack coat. No matter the location, the weather, or the time of day, EZ STREET cold asphalt is quick, effective, permanent, and requires a minimal installation crew. Simply sweep the area, fill the area with EZ STREET cold asphalt and compact with a shovel or car tire. It really is EZ!



Hollow Square Glass Block

The concerned variant of barrier is the monolithic construction made from hollow square glass blocks 190x190x80 mm, the thickness of the exterior walls of glass blocks is 8-10 mm. Glass blocks are laid row upon row. The horizontal cement joints with the thickness 10 mm between are reinforced with steel twigs of 6mm in diameter (2 steel twigs in every joint)..

Apart from supplying of all Equipments mentioned here, we can supply spare parts for all Equipments. The Spares Parts are Genuine as well as equivalent.

All filter requirements would be supplied from mostly HASTINGS & BALDWIN brands since we are the sole distributor for those brands.

You may contact us for any other parts or spare part which are not related to the products shown here. We have professional who can out source any kind of products and part/spare parts for same.



Qatar Development and Trading Co.
الشركة القطرية للتنمية والتجارة



Parking, Security,
Fire & Other Safety
Solutions

SECURITY & PARKING RELATED PRODUCTS

MODPARK® Valet Parking System:

MODPARK®, the MODular PARKing system, is the ideal solution Valet Parking System. We offer solutions for all your applications, whether you need a barrier for your company car park.

You need to manage small parking lots and large garages equally profitable? Do you need a secure parking area for your company vehicles? Do you wish to link several car parks to a parking guidance system? Do you wish to reserve special spaces for your customers? Do you wish to reduce nightly watch tours by your employees? Do you have to offer several payment methods? None of the above tasks are identical. They can be solved by one system, efficiently, reliably. MODPARK® is flexible and integrates different technologies. Select Know-how instead of effort.

The Modpark Easy system is easy to install, easy to operate, easy to maintain has three different terminals.

THE ENTRY GATE ...where a ticket will be issued. MODPARK® technology in an attractivedispenser design. The ticket dispenser TG-31 is particularly easy to operate from the car window – optimal for processing with smart cards and credit cards, with the well placed display and a rather discretely positioned intercom. The ticket dispenser TG-31 can be supplied with all function modules as desired.

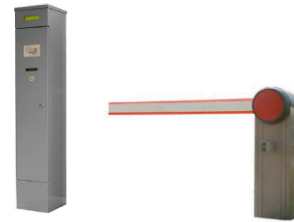

THE PAYMENT CENTER ...where the entry ticket is evaluated with barcode system and then issued a exit permit ticket with a grace period.

This is a PC based cashier terminal. It is available with ticket print or w/o print on the ticket. Both come with a receipt printer. The units is available for magnetic tickets or for bar code tickets.

The mask and menu driven operator interface is easy to learn, speeds up the cash process and offers protection against operating errors. An easy menu option allows to switch the unit from central pay to an exit pay functionality.

THE EXIT GATE evaluate the exit ticket for validity within the grace period and opens the exit barrier in order the exit from the car parking area

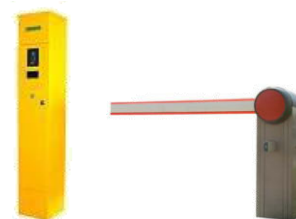

The parking system for smaller parking areas. Protects from misuse, keeps it free for your customers or your chance for revenue with free parking lots.

RIB Automatic Barriers Gate:

RIB Electro-mechanical Automatic Barrier for industrial entrances, and because of its powerful mechanical system, it can operate booms up to 7 m long. In the event of power failure, there is a practical handle for moving the barrier manually. Also, Barriers are available for both manual as well as automatic mode.

Model : RIB PRESIDENT

Barrier with boom long up to 3 or 4m which opens in 3 seconds complete of encoder to detect obstacle Suggested for 600 daily cycles



Model: RAPID PARK and RAPID PARK METAL

Barrier with boom long up to 3m which opens in 1,5 seconds Suggested for 2000 daily cycles

Model: RAPID S and RAPID S METAL - Barrier with boom long up to 3,4,5m which opens in 3 seconds and suggested for 1200 daily cycles

Model: RAPID N and RAPID N METAL - Barrier with boom long up to 3-4-5-6m which opens in 6 seconds and suggested for 1500 daily

cycles

NORMAL Model

Barrier with boom long up to 7m which opens in 11 seconds and suggested for 1000 daily cycles



INDUSTRIAL Model

Barrier with boom long up to 7,5÷12m which opens in 16 seconds and suggested for 300 daily cycles

STOPPER

Barrier with chain long up to 20m Suggested for 200 daily cycles. A new chain barrier for controlling park areas and passageways up to 20 m wide. It is equipped with 24V double motor and it can lift chain up to 60 kg weight.



UNIPARK is an Parking saver/automatic barrier that enables you to protect your reserved parking space and leave your vehicle with an additional security measure. In any setting, whether residential, industrial or collective. It allows you to open and close the barrier directly from the car using a remote control.

BOLLARDS:

A bollard is a short vertical post available in varieties of structures to control or direct road traffic, such as posts arranged in a line to obstruct the passage of motor vehicles.

Bollards Types

- Cast Iron & Cast Aluminium Bollards



- Steel Bollards & Stainless Steel Bollards



- Recycled Plastic Bollards



- Illuminated Bollards



- Traffic Bollards & Post Sleeves



- Ferrocast/Duracast™ Polyurethane (PU) Bollards

The Ferrocast bollards are manufactured from engineering grade polyurethane which is cast around a steel core.

This makes them virtually inert and the non-ferrous exterior means the bollard body will never rust, making them particularly suited to saline environments.





Crowd Control, Store Fixtures, Signage, Retail Displays, etc.

Public Guidance:

Beltrac stanchions are patented architecturally acclaimed public guidance posts. Constructed from a continuous extrusion attached to a weighted steel base, our Beltrac line of Public Guidance stanchions will withstand years of use in the field. Each Beltrac post is equipped with our unique, industry-first 4-way dovetail groove designed to receive retractable belts or other attachments. To protect flooring in the queuing line, all posts are supplied with a standard non-marking rubberized base. Designed and built in the U.S.A.

Traditional stanchions are classically styled crowd control posts, utilizing swag ropes to create a queuing line. Available in Solid Brass, Stainless Steel and a variety of painted (powder coated finishes). Our extensive variety of portable posts will enhance any decor. All posts are factory assembled and include a universal ring that accepts swag ropes from any direction.

Retractable Belt Closures are available with 7', 13' and 18' belts. The units are attached to the wall with efficient, small dimension back plates. These units are ideal for cash register closures, hotel corridor barriers and warehouse safety aisle closures and are available in variety of finishes and belt colors.



Hand Sanitizer Dispenser

Instant Hand Sanitizer Dispenser conveniently dispenses a non-allergenic, hospital-strength hand sanitizer that kills 99.9% of the most common disease-causing germs on the spot. It utilizes an alcohol-based self-evaporating solution, enabling hand sanitizing without the need for water, soap or towels. The dispenser works with gravity, not moving gears, lasting many years and requiring only minimal battery power.



Premium Sign Frames



Premium Sign Frames & Sign Inserts

Lavi features exclusive sign frames for mounting on top of crowd control posts. These frames are fabricated with radius corners, eliminating sharp edges near your customers. Each frame includes twin clear acrylic panels designed to accept regular paper media. Elegant sign stands feature a universal ring that accepts swag ropes from any direction. Frames are fabricated with radius corners, eliminating sharp edges near your customers. Each frame includes twin clear acrylic panels designed to accept regular paper media.



Smooth radius corners eliminate sharp edges near your customers.

Lavi Industries' sign frames are strong and durable yet stylishly designed. Sign Frames can accommodate an array of media options ranging from changeable letters to standard inserts. We offer a wide variety of sign frame sizes and options. Radius corners are standard for signs used on our Traditional and Beltrac stanchions to ensure your customers' safety.

Lavi Industries features exclusive sign frames for mounting on top of crowd control posts. These frames are fabricated with radius corners, eliminating sharp edges near your customers. Each frame includes twin clear acrylic panels designed to accept regular paper media.



Light Duty Sign Frames

These attractively priced frames serve your signage needs when less customer traffic is anticipated.

Sign Inserts

Sign panels provide an easy means of communicating with your customers. With our rapid in-house sign making capabilities, your custom message or graphics are just a phone call away



Other Traffic Signs

Regulatory Traffic Signs



Warning Traffic Signs



Guide Signs



School Traffic Signs



Road Construction Traffic Signs



Arrow Boards





Impact Protective for Wall & Door:

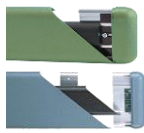

Wall Guard: cost-effective alternative without sacrificing impact resistance with an abbreviated aluminum retainer. Utilizes a non-PVC cover mounted on a continuous aluminum retainer. Coordinate interiors with 100 standard colors.

Corner Guard: Provide superior impact resistance with a cost-effective vinyl retainer that is nearly four times stronger than aluminum retainer and six times stronger than other vinyl retainers.

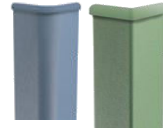

Handrails: Provides better gripping ability with ergonomically designed thumb groove. Choose from six metal finishes for thumb insert.



Wall Base: Provides superior impact protection with continuous foam bumper mounted on continuous aluminum retainer. Brand: Cape Cod.

Outdoor Security Barricade

Portable outdoor barricades are important safety and security equipment for crowd management at parades, stadium ticket lines and parking lots. Lavi Industries offers highly durable barriers that withstand the elements. Barricades are available in 6' and 8' lengths and are 45" high.



Parking Cones with high quality 28" PVC cones and UV absorbers to maintain the bright Original color. **Delineators** with 42" T-Top Delineator Post 3" reflective bands with 15lb base

Airport Construction Barricade

Our **Low Profile Barricades** can be ordered with orange and white reflective sheeting and can hold up to 2 flashing red lights per section. Airports worldwide use our barricades to mark off hazardous construction zones and ensure traveler safety.

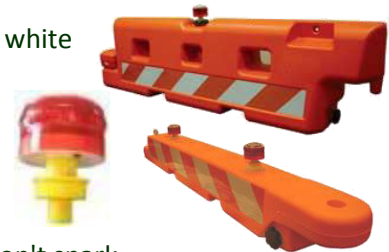

Foreign-object-debris free, in actual use they can stand up to jet blast. And since they're made of non-conductive material, they won't spark if struck by a metal object.



Crash Barricade

Our **Crash Barricades** can be ordered with orange, Safety Orange, Red and white colours. Special colours also available on request basis. These are water filled barricades can be chained with special accessories. Most economical barricades available with planks as well as high durable barricades with side panels and different sizes.



Speed Control Humps & Bumps



An oversized speed hump that is used to slow down vehicular traffic while maintaining continuous traffic flow. These modular Speed Humps are ideal for large areas such as parking garages, parking lots, apartment buildings, shopping malls, schools, hospitals, etc.

Parking lots are much safer when traffic moves slowly. Speed Humps help reduce vehicle speeds — and accidents!



Vehicle / Wheel Stoppers

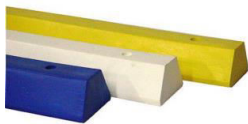

Solid High Impact Resistant Rubber provided with Yellow strip cover Strong enough to stop any car, van or the biggest pick-up truck. The yellow reflective stripes are highly visible during day and night.

The low profile construction provides that even the lowest cars are not going to damage bumpers or tires.



WORK SAFETY SOLUTIONS

Racet Safety Helmets

Tough and functional helmets available with manufactured by methods, **HDPE with low dome profile & rain channel and Impact Resistance UV stabilized High density Polythene.**

Also, adjustable methods are Fully Adjustable Polythene Harness & Webbing/Comfort Harness and 6 point harness, Fully Adjustable.

100% impact safety guaranteed.



Safety Spectacle & Goggles



EN166 Single lens polycarbonate spectacle. Modern lightweight style with scratch resistant lens.

Specifications:

- Polycarbonate single lens safety spectacle
- Scratch resistant
- 25gms
- Soft flat spatula type arms
- Intergrated polycarbonate nose piece
- Lateral protection
- Easy to use with safety helmet and ear defender

Ear Plugs

Ear Plugs are the ideal choice for protection of the organ of hearing in areas of continuous exposure to high levels of sound, and also ideal in hot and humid conditions. Choose from a comprehensive range of Ear Plugs which are all Internationally certified, CE Marked (Conforming to EN 352- 2: 2002) or ANSI Certified, and provide the highest level of comfort to the user, along with giving the optimum attenuation to harmful levels of Sound.



Resperatory & Safety Mask

Non-toxic dust and pollen comfort mask. Moldable metal noseband reduces fogging in glasses. Latex-free and hypoallergenic for users with sensitive skin. Heavy duty elastic strap keeps mask secure. Light green color highlights lawn and garden applications



Coveralls

We are supplier of many famous brands of Coveralls and all are 100% Cotton with various features in them.

Brands:

WORKSafe[®]
WORKLAND
RIGMAN[®]



Safety Vest



We also supply various brands of Safety Vest with different safety colours.

Available 100% polyester with tricot, knitted fabric, woven fabric, mesh fabric and other fabric as per your choice

Gloves

String Knit seamless gloves - 7 gauge knit with 2 thread

These are low cost natural color gloves made in economic weights of cotton blended knits and are sized to ensure comfort and a great fit. Very suitable for a variety of uses and are ideal as a liner under work gloves. Their seamless design provides warmth and reduces abrasion.



Leather Safety Work Gloves

Double Palm Leather, Double Stitched for Extra Safety, Cowhide Split Leather with Textile Cloth Back Fabrics. Rubberized Safety Cuff, Fleece Lined, Heavy Duty Work Gloves. Best for Multiple General Heavy Duty Workss

Safety / Work Shoes

Laceless Genuine Leather Work Shoes

Suitable for Executives and clerical grade staff.



Laceless Genuine Leather Work Shoes

Plastic injection moulding Buffalo leather 4" with steel toe, with steel sole campela lining PU sole.



Fall Protection System

Full Body & Sit Harness / Vests / Fall stop & arrest lanyards

In the situation where there is a secure anchor point above the user, and the user needs to be able to move about freely, a suitable fall protection system can consist of a fall arrester with a retractable cable which automatically recoils into the unit. In the case of a fall, the fall arrester unit automatically locks limiting the fall. Standard EN 360. Such a system can be effective for certain kinds of work within the industrial sector, likewise within construction.

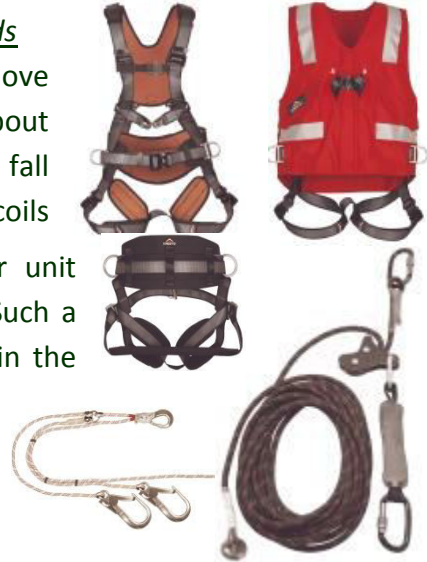

Stretcher / Evacuation Chairs



Stokes Basket Stretchers / Scoop Stretchers / Special Stretchers

Various kinds of stretchers available for various uses. Prices may vary depends on construction material.

Evacuation Chairs

With evacuation chairs, when the situation demands, a single user can assist in the evacuation of a colleague over stairs with a smooth, controlled descent with no heavy lifting or manual handling required.



Buoyancy Ring / Life Jackets

Stokes Basket Stretchers / Scoop Stretchers / Special Stretchers

Various kinds of stretchers available for various uses. Prices may vary depends on construction material.

Evacuation Chairs

With evacuation chairs, when the situation demands, a single user can assist in the evacuation of a colleague over stairs with a smooth, controlled descent with no heavy lifting or manual handling required.



Analogue Addressable Fire Detection & Alarm System



Compact analogue addressable panels

Fully comply with EN54:Parts 2 & 4 and can be specified with 1 or 2 detection loops, each capable of accommodating 200 devices comprising of repeat panels, interfaces, manual call points, sensors and sounders. A one to two loop panel accommodating up to 200 devices per loop. LCD display allows clear indication of fire or fault location. Site specific fire plans can be programmed to meet the evacuation needs of the building.

The LCD repeat panel indicates Fire, Fault and Disablement information either directly as events occur or by accessing the logs via dedicated keys. A maximum of 4 Repeat Panels can be connected to a Vigilon Compact control panel.



A range of low profile addressable devices to suit different applications. Heat Sensor - for steamy and dusty environments e.g. boiler rooms kitchens and laundries. Optical/Heat - detects smoke from a slow burning fire and/or heat from an intense fire producing little smoke.

An addressable call point with a response time less than 1 second. Versions available include:

- IP55 rated
- Lift up covers
- Keyswitch
- LPCB applied for





Qatar Development and Trading Co.
الشركة القطرية للتنمية والتجارة



Tools, Electricals, Lighting,
Tools, Electricals, Lighting,
Telecom, Sports & Educational
Equipment Solutions



TOOLS Solutions...

John Macdonald Air, Hydraulic Tools & Couplings

John Macdonalds has a long established reputation for quality and reliability and have been a leading manufacturer of pneumatic tools since 1884 in UK. At Macdonald, they continue to employ traditional, proven manufacturing techniques and materials while at the same time being highly innovative in our approach to designing and developing better solutions for the customers. Major components are machined from drop gorged alloy steel for maximum durability using up to date CNC equipment for maximum precision.

BREAKERS – Standard Models

Lightweight and maneuverable, the Macdonald pneumatic breaker has an excellent power to weight ratio. This makes it the ideal tool for a wide variety of light to medium duty demolition and narrow trench work.



21CLS



PB55S



284S



125S

BREAKERS – VR (Vibration Reduced) Models

This Modern Macdonald Vibration Reduced Breaker will suit any job, lightweight and maneuverable, the Macdonald Pneumatic Breaker has excellent power to weight ratio, this makes an ideal tool for a wide variety of light to medium duty demolition and narrow trench work.



15PVR



17PVR



19TVR



23TVR



24VRS



28SVRT



34VRS

BREAKERS – Spare Parts

Each and every part has its own genuine spare part.



DEMOTOOLS – Standard Models

The Macdonald Demolitions are the ideal tool for light duty demolition work in brick or concrete. Due to the hammer only action these tools will give reduced maintenance costs, harder hitting power and less spares requirements than hammer drill tools. They can be used with a range of standard accessories.



DM5S DM11S (Out Triggered) DM11S (Inside Triggers) DM12S (OT) DM12S (IT)

DEMOTOOLS – VR (Vibration Reduced) Models

This Macdonald Vibration Reduced Demo pick is ideal for demolition work in brick and concrete. The VR hosts versatility and low vibration levels combined in a single tool with Quick Change Retainer and 4 Bolt Back-head for increased durability.



CH4VRS DM11VRS (IT) CM11VRS (IT) DM12VRS (IT)
DM11VRS (OT) CM11VRS (OT) DM12VRS (OT) DP11VRS

DEMOTOOLS – Spare Parts

Each and every part has its own genuine spare part.

SCABLERS – Standard Models

The S1 single head hand held scabbler is the ideal tool for small awkward areas when removing laitence or for concrete repair work. The MSG3 triple head, hand held scabblers are designed for medium duty work in de-scaling, laitence removal and concrete repair. The Macdonald 1UF is a single unit hand operated pole Scabbler with the same power as a single unit of the heavy multitool Scabblers. The Macdonald U3 three headed & U5 Five headed trolley scabblers are specifically designed for surface work on concrete where it is necessary to carry out surface hammering without in damaging the basic concrete. The Macdonald LPS Tools can be used to remove tiles, paint, epoxy and bituminous coatings from floors, walls and other flat surfaces. The Macdonald NG10



SCABLERS – VR (Vibration Reduced) Models

The S1-VR single head hand held scabbler is the ideal tool for small awkward areas when removing laitence or for concrete repair work. MS3-VR Vibration Reduced triple head scabbler is designed for medium duty work in de-scaling, laitence removal and concrete repair. For surface preparation of small areas or areas close to walls or between re-bars, the 1UF-TV is second to none. Its also the ideal tool to compliment the U3-VR or the FB5-VR to scabbler edges where larger Machines cant reach. The Pneumatic Vibration reduced Crack Chaser is designed to follow cracks on concrete to allow for a clean refilling hole for the new material.



SCABLERS – Spare Parts

Each and every part has its own genuine spare part.

DRILLS – Standard Models

The Macdonald 1615 Rock Drill is lightweight and compact and is therefore ideal for pop holing, gas work and gives excellent service in confined spaces. It is designed for hand drilling holes suitable for blasting operations in mines and quarries and is capable of being used on rocks of varying hardness. The 1615 will drill a 34mm diameter hole up to 1.5 metres deep. The Macdonald 2315 Rock Drill is a medium weight tool designed for drilling holes suitable for blasting operations in mines and quarries and is capable of being used on rock of varying hardness. The tool will drill a 45mm diameter hole up to 4 metres deep or 42mm diameter hole up to 6 metres deep.



1615



2315

DRILLS – VR (Vibration Reduced) Models

The DR4VRS is our lightweight hammer action rotary air drill capable of drilling into the hardest concrete or stone. The Macdonald 1615V Rock Drill is lightweight and compact and is therefore ideal for pop holing, gas work and excellent for confined spaces. The Macdonald 2315V Rock Drill is a medium weight tool designed for drilling holes suitable for blasting operations in mines, quarries and is capable of being used on rock of varying hardness.



DR4VRS



1615V



2315V

DRILLS – Spare Parts

Each and every part has its own genuine spare part.



John Macdonald Hydraulics

The Macdonald 209 hydraulic 20litre breaker can be used for breaking concrete, asphalt and brick with maximum operator comfort and minimum exposure to vibration.

The accompanying 20 litre power pack has been designed and developed for ease of use and servicing. The modular design housed within a strong steel frame ensures a high level of durability and long life.



The Macdonald 313 hydraulic 30litre breaker can be used for breaking concrete, asphalt and brick with maximum operator comfort and minimum exposure to vibration.

The accompanying 30litre power pack has been designed and developed for ease of use and servicing. The modular design housed within a strong steel frame ensures a high level of durability and long life.



John Macdonald Couplings

QUICK ACTION – Standard Couplings

Macdonald STANDARD QUICK ACTION Couplings are bayonet style which are used in pairs. A pair comprises a Female and Male coupling which are connected together by a push and quarter turn. Once connected, the spring loaded sleeve of the male coupling prevents accidental disconnection. Direction of fluid flow is from female to male on all Macdonald Quick Action Couplings.



Female Coupling



Male Coupling

Air Valve Couplings

This is a one way shut-off coupling incorporating a valve which automatically shuts off fluid supply, upon disconnection of the male from the female coupling. A valve inside the female coupling opens when the couplings are connected and closes when they are disconnected. Available in 'reverse flow' direction if required.



Female Coupling



Male Coupling

Air-stopper Couplings

If a hose bursts or a coupling downstream of the Airstopper becomes disconnected accidentally, flow through the Air-stopper is automatically and immediately stopped, thereby avoiding hose whipping or snaking. After closing automatically the Airstopper allows a small bleed of fluid to flow through its disc valve to warn users that the system is still live. The Airstopper may be likened to a Fuse in an electrical circuit. Available in 'reverse flow' version



Female Coupling



Male Coupling

Whip stopper Couplings

The Whip-stopper coupling incorporates a disc valve which closes automatically if a hose bursts or a coupling disconnects accidentally downstream of a Whip-stopper. After closing automatically the Whip-stopper allows a small bleed of fluid to flow through its disc valve to warn users that the system is still live.



Female Coupling



Male Coupling

Sleeve-turn Couplings

The Sleeve-turn feature enables the Female coupling to rotate through 360 degrees relative to the Male whilst connected, thereby avoiding hose twisting or kinking.



Female Coupling



Male Coupling

Sleeve-lock Couplings

The Sleeve-lock feature consists of a screwed ring which locks on the male coupling body just behind the sliding sleeve after connection of the two couplings, this reduces the risk of accidental coupling disconnection.



Female Coupling



Male Coupling

Fire Hose Reel Couplings

Macdonald Quick Action Fire Hose Reel Couplings are designed to wrap readily around "First Aid" high pressure hose reels. They are compact and allow maximum water flow rates through standard bore hoses. Like Standard Quick Action couplings they consist of a Female and Male half which are easily connected with a simple push and quarter turn action. This allows the spring loaded locking sleeve on the male coupling to spring forward and create a secure connection. Disconnection is achieved by pulling back the locking sleeve and giving a quarter



Female Coupling



Male Coupling



Qatar Development and Trading Co.
الشركة القطرية للتنمية والتجارة

ELECTRICAL Solutions...

We distribute of Electrical equipments, devices, apparatus, etc. etc. for all your day to day industrial needs.

Contactors

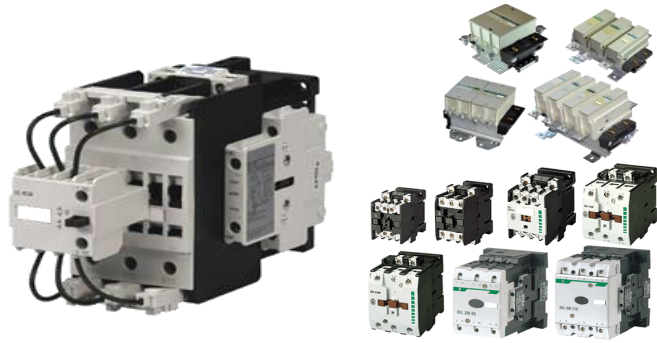

Relays



Thermostat



Blades



Cables & Clamps



Condenser Fan Motor



Connectors, Glands



Control Gear



Drill / Driver



Embedded & Wireless



Enclosures and Fans



Fuel Pumps



Hot-melt Glue Gun





Qatar Development and Trading Co.
الشركة القطرية للتنمية والتجارة

HVAC and Security



Igniters & Ballast



Transformers



Multi-meters



Motors - Electric



Pneumatics & Hydraulics



Power Supply Unit



Process Control



Pumps



Switches and Indicators



Scope-meter



Socket Set



Soldering Stations



Table Vises



Test and Measurement



Tools





Qatar Development and Trading Co.
الشركة القطرية للتنمية والتجارة

Transformers



Workshop and Site Equipment



Workshop Consumables



TELECOM Solutions...

Single Fiber Fusion Splicer



Model FSM-60S Single Fiber Fusion Splicer with following standard accessories as a Complete Kit. The accessories are...

- Fiber Cleaver High precision fiber cleaver CT-30A
- Primary Coat Stripper (for 250nm fiber) PS-02
- Jacket Stripper (for 900nm fiber) JS-01
- Loose Tube Cutter LTC-01
- Protection Sleeves (250pcs/pack) FPS01-900-45
- Hand Rap Alcohol Dispenser HR-02

Handheld OTDR Model M200-K-QUAD for Single Mode (1310, 1550) and Multi Mode (850, 1300)

The Noyes M200 from AFL Telecommunications offers unmatched OTDR capabilities in a handheld package weighing less than 1 kg (2 lb). Multimode, Single-mode, and 'Quad' wavelength models are offered.

This unit is available with...

- Integrated Visual Fault Locator
- CompactFlash™ memory card
- Trace analysis PC software CD
- AC adapter (Part no: 6000-00-0015 UK type)
- User's guide
- Soft carry case
- plus switchable adapters SC (2 for QUAD models), FC and ST adapters
- USB Cable



LIGHTING Solutions...

Special Outdoor Lighting & Fittings:

We also supply **Outdoor Lighting & Fittings** they are specially used in Parks, Industrial Parks, Security (zone requiring ensure high safety), Objects Architectural, Sporting Sites, etc, etc. Our supplies includes High Mast Flood lights for most other government institutions and foreign diplomatic agencies, embassies, etc. Up to 2 meter Submerged bronze light fittings available with optional stand.



Task Lights are available in floor or tripod models.



Another light fitting is **Double Flash Beams** with excellent light exposure values and exceptional low height of only 95 mm and can be mounting into any vehicle.

Explosion Proof Lights:

These lights & fixtures are for any Explosive Atmosphere Location! This product has five different hub entries at each end enabling the installer to wire the fixture for more desirable angles than a single entry. The center located ballast allows for a more balanced fixture for ease of installation and weight distribution. Available in 2' & 4' lengths for 2, 3, & 4 lamp combinations in T5, T5HO, T8, T8HO, T12 & T12HO.



Traffic Control Torch

A compact multi function LED torch with screw in traffic control wand attachment giving it 3 modes of operation. The torch has two operating controls at either end, one operates a white LED torch feature, the other operates either a red flashing or green constant LED.



Made from aluminium the traffic control torch is sturdier than other wands in our range and so is more suited to being carried daily on your equipment belt. In torch mode this unit has a surprisingly powerful LED, which provides a wide beam with no dark spot unlike incandescent light bulbs. Life span and efficiency are also superior to traditionally illuminated torches and the unit is lightweight due to reliance on 4 x AAA batteries.



Qatar Development and Trading Co.
الشركة القطرية للتنمية والتجارة

LAB, MEDICAL, EDUCATIONAL EQUIPMENTS & APPARATUS

We distribute of Laboratory Medias, Apparatus, Instruments, Equipments & Chemicals, Reagents, Standards, Consumables for laboratories & production.

We also offer a comprehensive selection of safety products from leading manufacturers, providing head-to-toe protection. From eyewear, gloves, coats and masks to storage cabinets, first aid products or hazard data information.

- Autoclaves
- Beakers
- Brushes
- Carts
- Clamps and Supports
- Containers
- Cylinders
- Distillers
- Filters
- Funnels
- Hot Plates and Stirrers
- Incubators and Ovens
- Lab-ware Sets
- Meters
- Micro-technique
- Mortar and Pestle
- pH Tests
- Plates
- Racks
- Safety Supplies
- Scoops, Spatulas, and Spoons
- Spectrophotometers
- Stoppers
- Thermometers
- Tongs
- Tubes
- Vials
- Balances
- Bottles
- Burners
- Centrifuges
- Condensers
- Crucibles
- Desiccators
- Electrolysis
- Flasks
- Hoods
- Hydrometers
- Jars
- Lighting
- Microscope Slide Supplies
- Mixers
- Osmosis Apparatus
- Pipettes
- Pumps and Vacuums
- Refrigerators and Cooler
- Scales
- Sieves
- Stirring Rods
- Syringes and Needles
- Timers
- Trays
- Tubing





Qatar Development and Trading Co.
الشركة القطرية للتنمية والتجارة

AIR-CONDITIONS & SPARE PARTS:

QDT has been helping companies fill their air condition needs and we have provided assistance to clients around the country.



Selection:



We carry air condition parts and equipment for all major brands. From the most popular products to hard to find individual parts, QDT should be your first call.

Expertise:

With the millions of branded products available today it is important to work with a provider who has the expertise to recommend the product that best matches your needs.

We also involved in Electrical, Chemical, Mechanical, Ceramic, and etc, etc. items. You can contact us for fast, prompt and reliable services promptly.



Our Prestigious Clients

1. Doha International Airport
2. Qatar Foundation
3. RasGas Company Limited
4. Qatar Navigation
5. Hamad Medical Corporation
6. Qatar Petroleum
7. Qatalum
8. The Pearl Qatar
9. Gulf Helicopters
10. Qatar National Olympic Committee
11. Qatar Fertilizer Company
12. Qatar - Qatar Steel Company (Q.S.C.)
13. Qatar Primary Materials Co
14. Woqod
15. Cybarco Qatar LLC
16. Imperial Trading & Contracting Co.
17. Beton WLL
18. Marcegaglia Qatar
19. Con-X-Ion Logistics Heavy Equipments
20. Qatar Beton
21. United Development Company (UDC) PSC
22. Qatar Motor & Motorcycle Federation
23. Al Wataniya Concrete
24. Al Jaber Heavy Lift & Transport
25. Boom Construction Company
26. Al Farhan Est.
27. Gulf Housing & Construction
28. Jarjour Rental Machinery
29. Manlift Middle-East LLC
30. Khalid Cement industries Complex
31. OHL/Contrack JV
32. Redco International
33. Simplex Infrastructures Limited
34. Sinohydro-Gamuda JV
35. United Readymix
36. United Equipment Rental
37. National Petroleum Services Co. (K.S.C.C)

